

*International Edition*

Free,  
electronic magazine  
for railroad enthusiasts  
in the scale 1:220  
and Prototype

[www.trainini.eu](http://www.trainini.eu)

Published monthly  
no guarantee

ISSN 2512-8035

# Trainini

German Magazine for Z Gauge



Small meets large in the Black Forest

Finale for the Water Tower  
Variety for the Tender

## Introduction

Dear Readers,

Today is a debut for me: my first foreword for **Trainini®**. Somewhat unfamiliar, but I'm going to do it. In this edition you will also find a news item about me as a new member of the editorial team.

September 2023, outside temperatures around 24 degrees Celsius. Not exactly the time to hole up in the basement train hobby room. But, nevertheless, we want to give you lots of ideas for the active crafting season that will come soon.

One must have ideas! This is what the small series manufacturer NoBa-Modelle has thought and has taken up the topic of the "tender," which has been unsatisfactory for many years. With a new tender construction, we want to show how a great unitary tender from DRG times can be constructed. Maybe the mass-production manufacturer will jump on this subject?

With our building construction series by Jochen Brüggemann we have now arrived at the last episode. In our opinion, it was a very successful project, and we wish all of you a lot of success with the reconstruction and, of course, fun with the crafting.

With the book on the history of the Prussian G 10 we present a new publication from the "blue series" of the Eisenbahn-Kurier. The author Hans-Jürgen Wenzel shows us the history of this class on a high professional level. Volume 1 is presented this month. Volume 2, which continues the history of the locomotive type from 1945 onwards, will also follow in a later edition.

As promised, we would also like to present the second part of the book on Diesel railcars from VGB | Geramond, which was published one and a half years ago. With the title "Verbrennungstriebwagen der Deutschen Reichsbahn – Triebwagen in Leichtbauweise von 1932 bis 1945" (Combustion Railcars of the German Reichsbahn – Railcars in Lightweight Construction from 1932 to 1945), the editors received a very factful and high-quality book that can be helpful in many ways.

With a visit to the Eisenbahnmuseum Schwarzwald (Black Forest Railway Museum) in Schramberg and this year's special exhibition "Small meets big", we have documented one of the highlights of this year in photos and text for you. Our Z gauge is very well staged there with Eckard Jehle's home layout. Fortunately, it is permanently available to this museum as an exhibit. In any case, we think that the museum, which is run by dedicated model railway enthusiasts, is always worth a visit.

Of course, the seasonal new products of our Z gauge suppliers must not be missing, which we will of course also present in detail in this edition. More will certainly follow in the next few weeks, as the exciting period of our hobby is only just beginning.

Finally, I had to note with a wink that our editor-in-chief did not present an aircraft model this time, or hid it so well that even I did not find it. On that note, I wish you a lot of fun reading, always joy and humour as well as a steady hand when modelling.

Sin-Z-erely,

Harald Fried



Harald Fried  
Editor

## Editorial

Introduction ..... 2

## Model

You have to have Ideas!..... 4

## Prototype

Currently no items

## Design

Up to the Water Tank.....23

## Technology

Currently no items

## Literature (not translated - only in German)

Powerful Lightweight .....19

Links to High-Speed Railcars .....21

## News

Very small meets very big.....41

Zetties and Trainini in Dialogue.....50

Imprint.....68

We thank Jochen Brüggemann for his contribution and the Eisenbahnstiftung for their photo support.

Date of publication of the German language version of this issue: 29 September 2023

### Cover photo:

The 1:32 scale model of the 232 TC 401, a Prussian T 18 once in service with the SNCF, meets selected Z gauge vehicles from almost three decades in Schramberg. The contrasts provide the special contrast of the exhibition.



## Tinkering for version diversity **You have to have Ideas!**

*In Märklin's Z gauge programme, among many tenders, there is also an extremely aged 2'2' T 34, which has been the standard for unit locomotives in the range for 51 years. However, its prototype only appeared in 1939 together with the class 41 and is therefore not at all suitable for the period of the Reichsbahn from 1925 until the outbreak of war. We want to address this shortcoming with a tinkering idea.*

It seems to make one's hair stand on end: "Thinking in terms of trains" is a frequently emphasised guiding principle of our regular supplier Märklin. However, if we look at the new products brochures that appear several times a year, the total number of new locomotives and wagons seems to be almost identical.

These striking ratios leave no doubt about the basic level of margins in the individual product sectors that a commercial enterprise needs to cover its costs and generate a reasonable profit.



The photo of box tenders on DRG unit locomotives is far more colourful than manufacturer Märklin would have us believe: here 41 032 (with old construction boiler) from the Rheine depot was photographed in Münster (Westf.) Gbf on 11 April 1968. Coupled to it is a riveted 2'2' T 32, which it only received after 1945. Photo: Bernd Kappel, Eisenbahnstiftung

In view of this incalculable importance of locomotives in the range, it seems particularly incomprehensible that a 51-year-old tender model that has not been reworked or repaired to its advantage is still being dragged through the programme today and repeatedly becomes part of steam locomotive novelties.



We are talking about the unit tender 2'2' T 34, which first saw the light of day in 1972 as part of class 003 (item no. 8885). It lacks the coal box elevation that is often mounted on the prototype and, after reworking also fine lanterns. The inlay, which was battered almost two decades ago and insufficiently repaired, is more reminiscent of roughly hewn pieces of rock than of lumps of hard coal.

Equally serious, however, is the fact that the prototype for this tender did not see the light of day until 1939. With the exception of the three-axle, riveted tender for the "Steppenferd" (class 24), Märklin still does not have a single one in its construction kit that can be coupled with a standard steam locomotive for previous years.

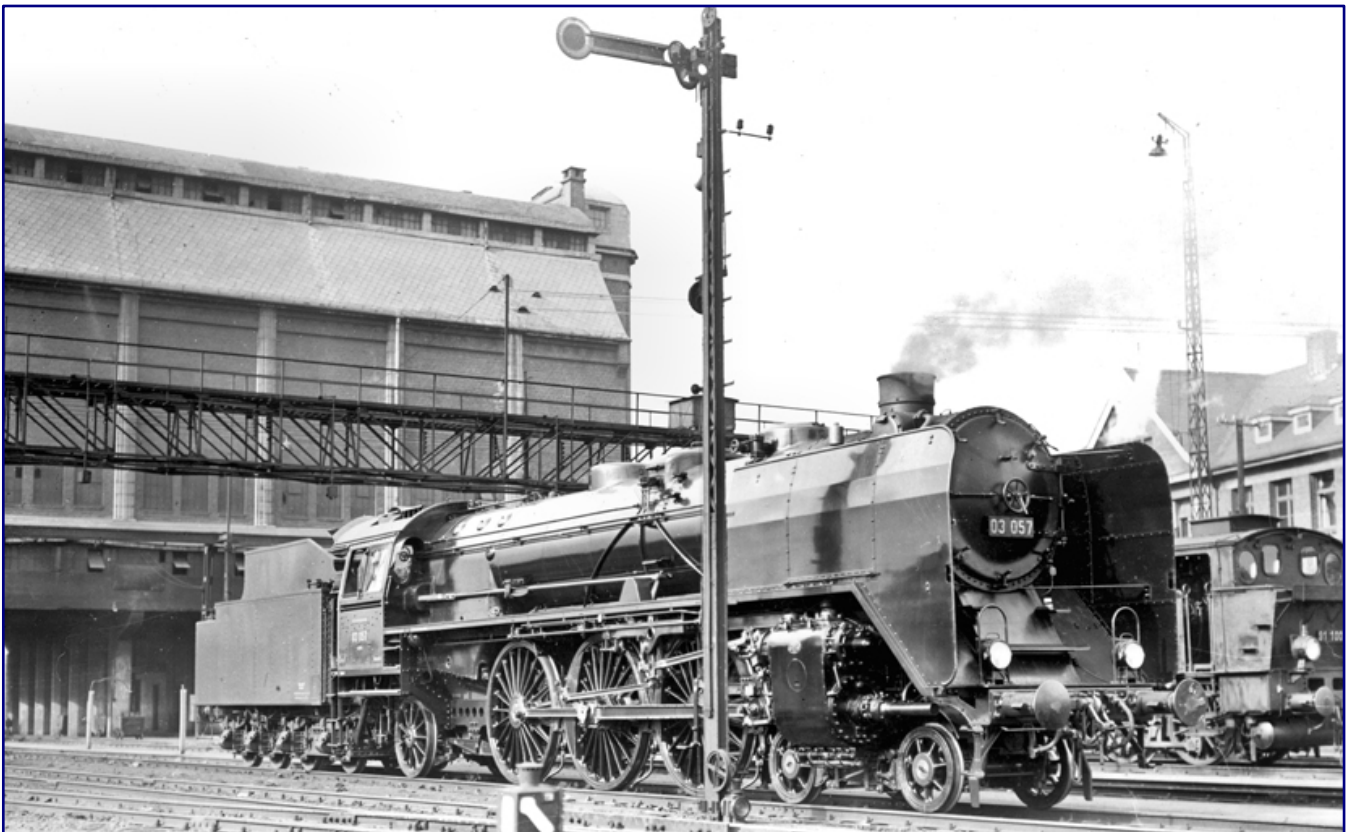

The DRG's first new development was still strongly oriented towards Bavarian tenders. The 03 057 of the Dortmunderfeld depot, photographed in front of the high bunker of the Cologne depot, was coupled with the 2'2' T 30 on 21 March 1936. It received the tender with only one bogie and two rigid axles later, because in its home depot only a 20 m turntable was available. Photo: DLA Darmstadt (Bellingrodt), Eisenbahnstiftung

And this gap in the programme is not small: the history of the unit locomotive began in 1925 with the 01 and 02 series, which makes 14 years that cannot be represented. The dilemma also reveals itself when looking at the number of series and total numbers of units, because it affects all locomotives with trailing tenders up to the appearance of the class 41, which was converted in the current procurement process.

Only for the class 50 (and not offered 23), which also dates to 1939, is there again an offer, which was designated as 2'2' T 26. In a nutshell, this means the missing possibility to offer the class 01 parade locomotive, its lighter sister class 03 and the heavy class 44 triplet locomotive prototypically with "Deutsche Reichsbahn" plates.

Even if the number of Epoch II enthusiasts who are directly affected by the gap in the range as model railway enthusiasts may be continuously decreasing and may not justify an injection moulding new product on its own, we see a need for action here.

The expected solution is a tender design that stands out from the museum-ready box tender at first glance. At the same time, it could use an existing running gear and save development costs here as well as take up shape variants for individual design differences with a well thought-out construction that relies on exchangeable sliders.



In front of the FD 23 (Hamburg - Berlin), the photographer had probably expected a class 05 locomotive, but instead it was 03 038 from the Bw Hamburg-Altona that led him on 2 August 1938. Taken between Zernitz and Neustadt (Dosse), its tender 2'2' T 32 of 1926 design, which we are making a model subject today, is also well featured. Photo: RVM-Filmstelle Berlin (Bellingrodt), Eisenbahnstiftung

But all this remains a pious appeal, which has not been heard in Göppingen so far, and in parallel must also come up against an existing budget. Until then, only self-help can offer a way out, which we would like to demonstrate here today with the help of Märklin and small series parts.

First, however, we would like to briefly touch on the development history of the DRG's four-axle box tenders up to 1939 in order to make our explanations both clear and comprehensible.

## Larger box tenders

Important construction principles of box tenders should be explained in advance in order to be able to clearly distinguish this type of construction. The central construction element is a rectangular water tank, the sheet thickness of which was mainly oriented towards sufficient corrosion resistance. On the inside, they were reinforced with transverse trusses.

Perforated plates on them also served as surge plates, i.e., they dampened the water moving when starting and braking, but allowed for equalisation and thus an identical level in the entire tank. When the



41 010 (Mönchengladbach depot) restored in 1950 at the Duisburg Hbf depot, which was closed in 1966. In the meantime, the steam locomotive has also given up its tender and received a 2'2' T 32 in exchange. 38 3772 and 42 1507 can be seen in the background. Photo: Willi Marotz, Eisenbahnstiftung

tenders, the term, by the way, comes from the English language, became larger, they were also fitted with longitudinal undercarriages to provide the necessary stability.

The ceiling of the water box also forms the floor of the coal box, which was built on top of it. At the front of the tender was the coal extraction point, called the shovel plate and placed 500 to 600 mm above the driver's cab floor. An uncontrolled falling of the coal was prevented by sluice doors, typical especially for Bavarian designs, or facing boards.

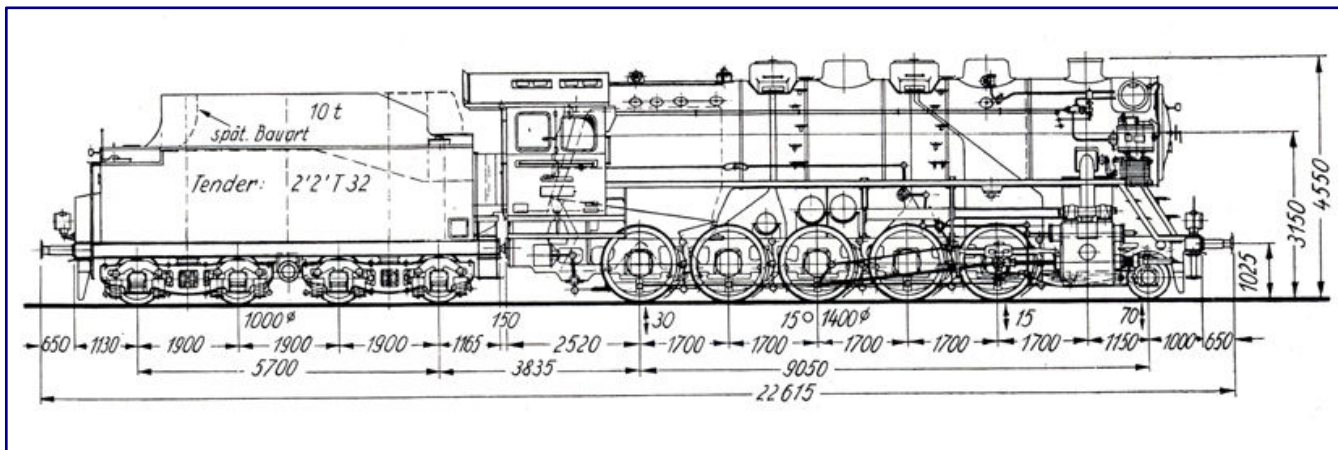

The class 43 was also coupled with the tender 2'2' T 32. The drawing in the Merkbuch für Trariefahrzeuge even marks the outline of the two last designs of this tender. Drawing: Deutsche Reichsbahn, DV 939 Tr (Ausgabe März 1962)



The water inlets were usually located at the end of a tender. The position (in the middle or on the outside) changed in the course of time and development. The height of the DRG's standard tenders was 3,000 mm above the top of the rails. With regard to water cranes of old national designs, additional emergency inlets were required at a height of 2,750 mm above the top of the rails.

The water tank with the mounted coal box rested on a stable frame of long girders, which was made torsion-resistant by the buffer beam and cross girders. The cross members were located in the centre of the tender and at the level of the pivots, if a bogie was to be found there. Otherwise, there were axle bearing cut-outs in the frame cheek.

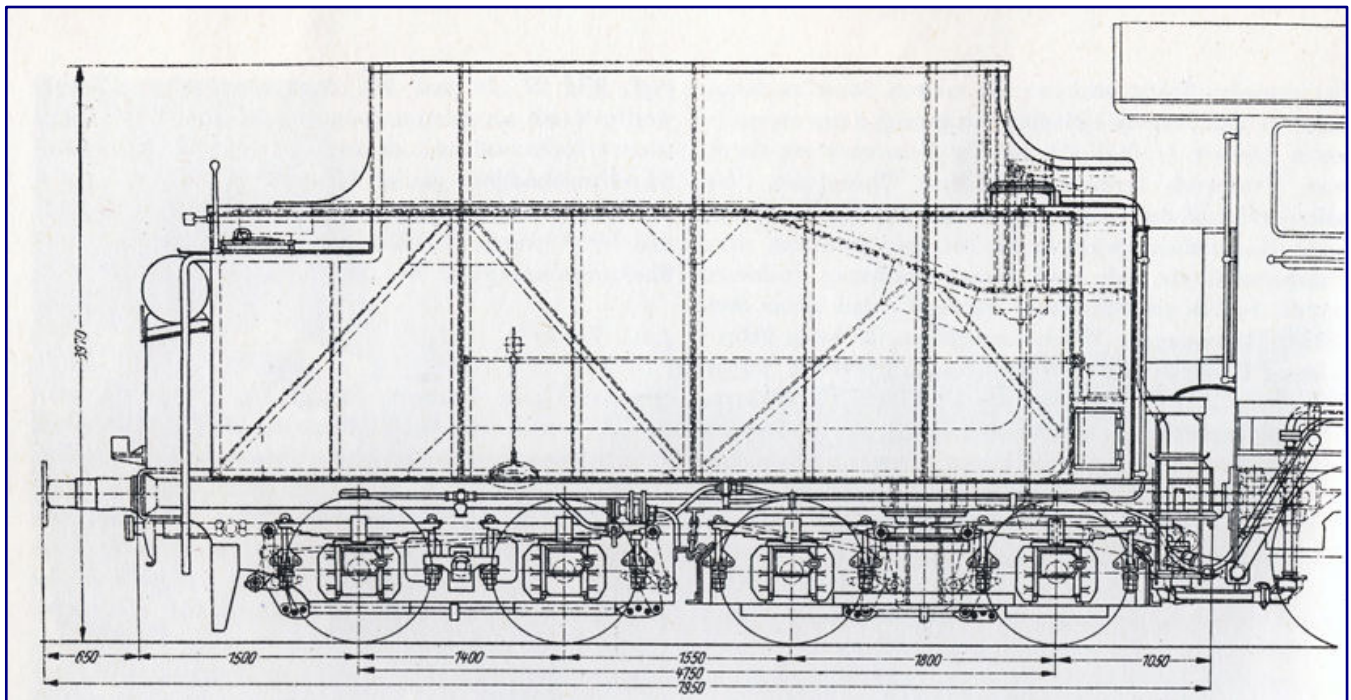

The first four-axle unit tender, first designated as the 4 T 30 and later as the 2'2 T 30, still borrowed heavily from Bavarian designs. This is clear from the box bogie with an axle base of only 1,800 mm, which is clearly different from the subsequent unit bogie, and especially from the rear, fixed axles with only 1,400 mm distance from each other. The short construction and the low water inlet at the rear were due to the still common turntables and water cranes from the Länderbahn era. Drawing: Deutsche Reichsbahn-Gesellschaft (RZA)

Decisive demands on the running gear were above all the maximum limitation of the total axle base of a locomotive (due to the turntable length), the maximum wheelset load (due to superstructure limitations), sufficiently large supplies for the chosen boiler of the locomotive, the required load braking and running smoothness with regard to the intended maximum speed.

It becomes clear at this point that the development of suitable tenders, which tended to be larger, also had to keep pace with that of the DRG unit steam locomotive. Nevertheless, the Special Locomotive Committee paid little attention to them. The locomotive factories based their designs very much on the Bavarian state railway engines.

Their primary focus was to ensure that the large standard locomotives could also be accommodated on the 20-metre turntables that were common at the time. But the focus was not limited to the Bavarian wheelset arrangement alone. The lock doors also became the standard for the time being, although not unanimously. Likewise, the Bavarian template prevailed in the arrangement of the clothing and tool lockers.

Contrary to all the principles customary there, the Prussian constructions were alleged to lack order and structure in the storage of clothes and tools. Tools in particular were left lying around in disarray and often required a complete clearing out when searching for them.

The first result of the consultations was the unit tender 2'2 T 30, which was delivered with the ten types of the 01 and 02 series from 1925. As typical Bavarian features, it had the aforementioned lock doors and only one bogie, the rear two were rigidly mounted in the frame. It was only a transitional solution, chosen with a view to the 20 m turntables.

## Bogies and welding technology

Already in the same year, another tender followed, which now had two bogies. It also held 10 t of coal, but now already 32 m<sup>3</sup> of water. Subsequently, called the 2'2' T 32, it belongs to the type of construction that we have made our model topic today.

Unchanged from its short-lived predecessor were the rivet construction and plain bearings of the axles. However, its axle base had increased by 950 mm to 5,700 mm, which initially limited its use. Initially, it was only coupled with the model locomotives of the 43 and 44 series, which were shorter than the two express train series and could therefore still be turned on a 20 m turntable.

The appearance of the coal box in the 1925 design still corresponded to the 2'2 T 30: The ends of its side walls were rounded towards the driver's cab side. This already changed with a first revision in 1926 (1926 design). The side walls of the coal box now ran in a slant towards the driver's cab.

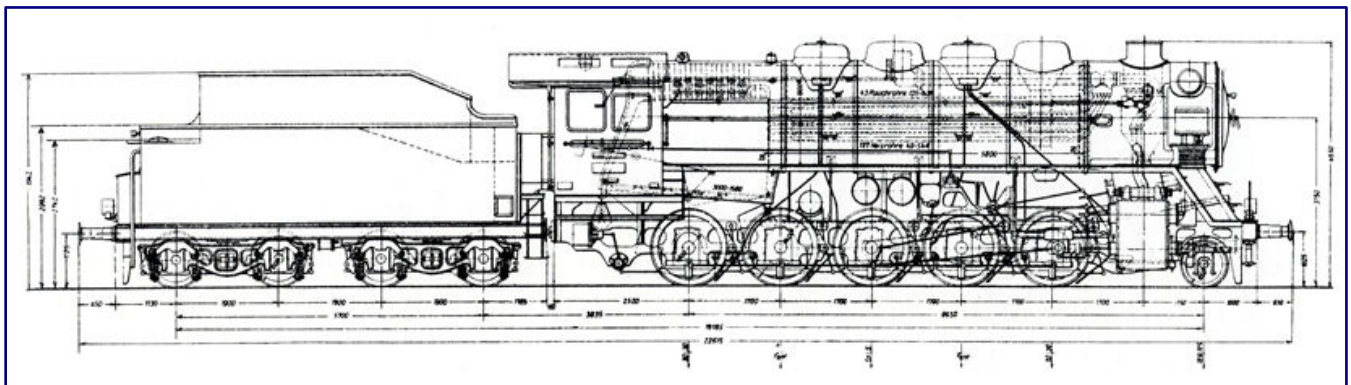

Since the 43 and 44 series were shorter than the standard express locomotives, they could be equipped with the longer tender 2'2' T 32 from the beginning. With the older 1926 design shown here, template for NoBa models, the machines were delivered starting with 44 013. Drawing: Deutsche Reichsbahn-Gesellschaft (RZA)

While the axle stands and overall length remained identical and the lock doors, which were unpopular with the personnel, were retained, a saving of 1.9 t could be made in the weight. With this 2nd design of the 2'2' T 32, which was the template for NoBa models, the locomotives 01 012 to 101, 03 001 to 162 as well as series machines of the classes 43 (from 43 011) and 44 (from 44 013) were put into service.

Another revision of the tender, which sometimes leads to irritation in the technical literature because of its designation "new design 1926" in the instruction books, took place in 1934. Instead of "2nd design 1926" it would therefore have been more accurate to designate it as "design 1934". This tender was also riveted and equipped with sliding axle bearings.

continues on page 12



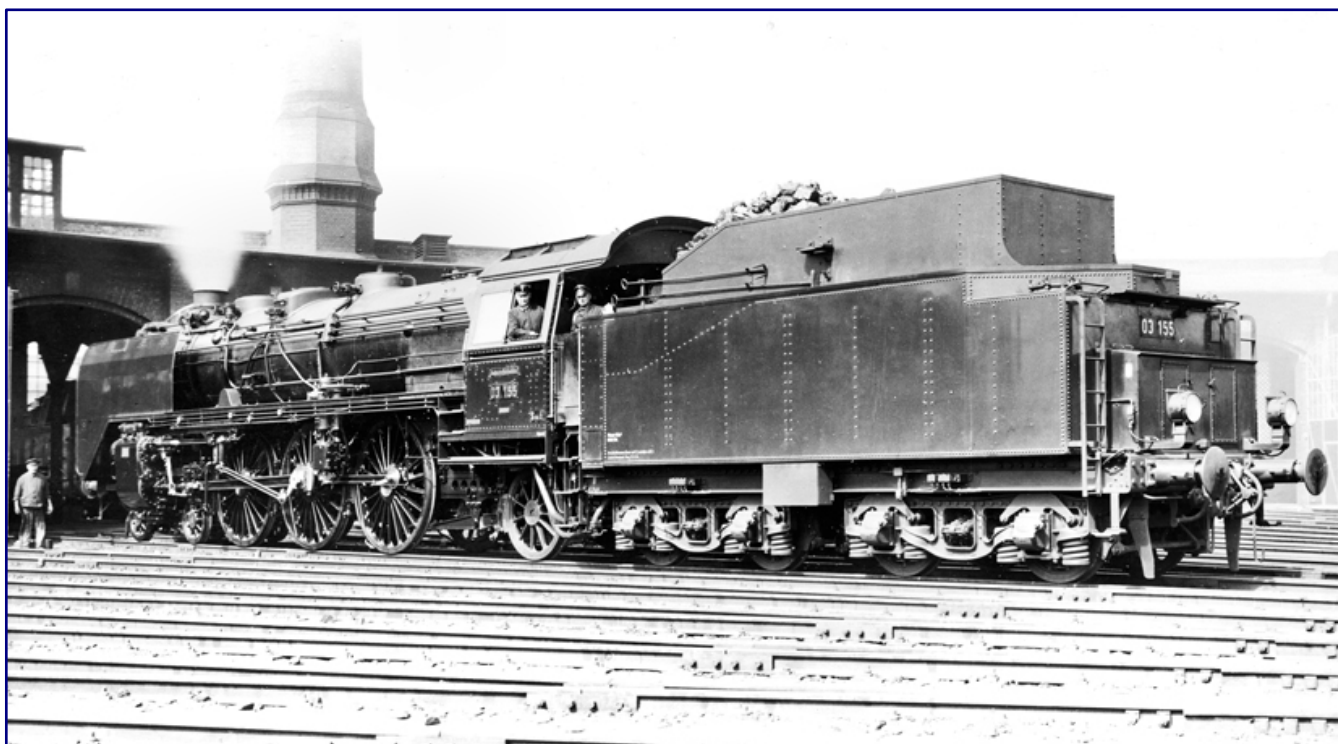

Photo above:

01 089 (Bw Hamm P) is a guest at Bw Köln Bbf on 9 August 1931. Besides the missing surface preheater, an indication for a steam injector of the Friedmann company, the tender 2'2' T 32 in design 1926 of an older version is noticeable. Photo: DLA Darmstadt (Bellingrodt), Eisenbahnstiftung

Photo below:

03 155 is also coupled unchanged with this unit tender when photographed at Leipzig Hbf West depot on 2 October 1935. Photo: DLA Darmstadt (Hubert), Eisenbahnstiftung





**Photo above:**

On the Cornberg ramp we see 44 1392 (Bw Göttingen Vbf) from DB stock, still equipped with a 2'2" T 32 type tender on 21 April 1961. The open water box lid illustrates the central position, the opening lower down the side is an emergency inlet. Photo: Joachim Claus, Eisenbahnstiftung

**Photo below:**

03 293 rushes through Königsmoor station on the Bremen - Hamburg line as a replacement locomotive on 23 June 1954 with F 33 "Gambrinus". Her tender at 44 1392 is a 2'2" T 32 of second design 1926. Photo: Walter Hollnagel, Eisenbahnstiftung

An external difference was again the coal box. Its side walls were higher and angled inwards at the upper edges. Towards the driver's cab, they were pulled through to the front edge. It was coupled for the first time with the locomotives 01 102 and 03 163, and was also frequently encountered after the Second World War.

In 1936, the 2'2' T 32 underwent its last development leap. In all dimensions and its exterior, it still corresponded to the design of 1934, but now it was a welded construction instead of a riveted one.

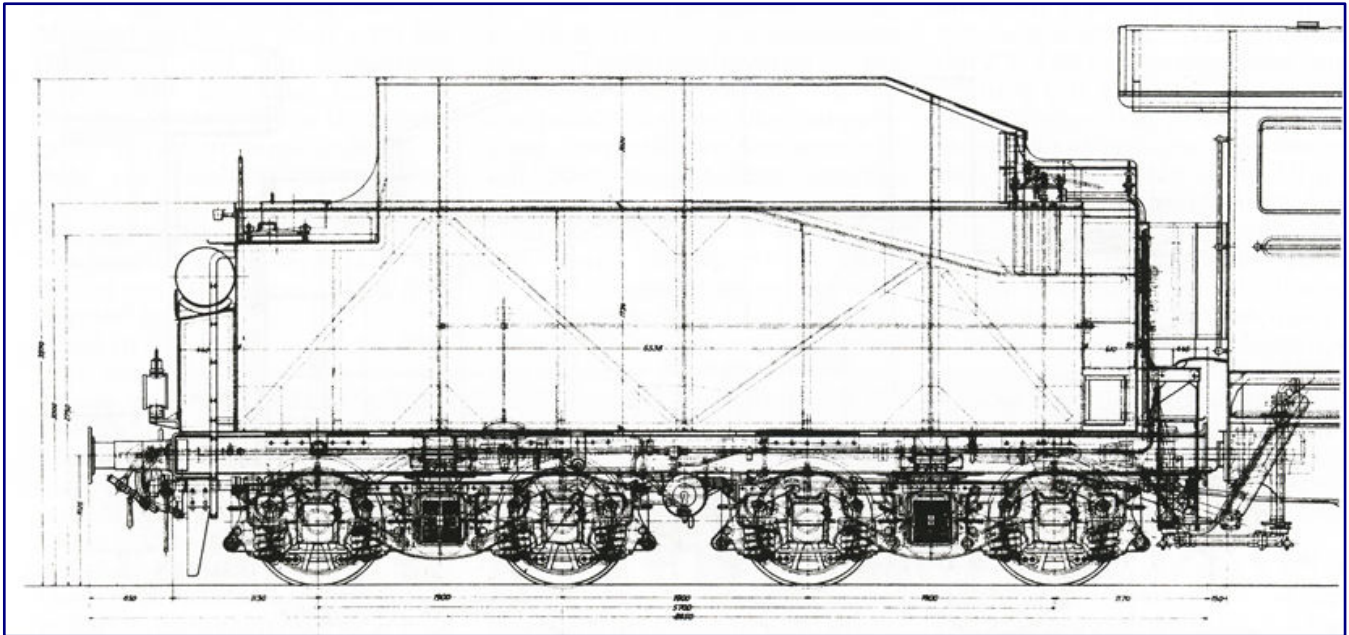

The RZA drawing illustrates the features of the unit tender 2'2' T 32 in the older 1926 design. The forward sloping side wall of the coal box, like the curved line of the 1925 design and the 2'2' T 30, was due more to an expression of dynamism in the taste of the time than to function. As it caused air turbulence and dirty cabs during fast journeys, another modification followed. Drawing: Deutsche Reichsbahn-Gesellschaft (RZA)

This resulted in a weight saving of 2.4 t, which reduced its unladen mass to 30.2 t. With the same axle pressure, its water tank capacity could therefore be increased from 32 to 34 m<sup>3</sup>, which cannot be read from the official designation.

Both the 1934 and 1936 designs had new boards instead of sluice doors at the coal tapping point. This was the RZA's reaction to unauthorised conversions by some depots that had simply built such boards between the permanently open sluice doors. Only fourteen steam locomotives were delivered with the last design of 1936: 03 254 to 261 and 03 270 to 275.

The reason may have been that a new design benefited from the advantages of the welded construction: the 2'2' T 34, which was first seen on a locomotive in December 1938 and which formed Märklin's template for its tender established in 1972. This was the 41 003, which entered service with this tender in 1939. It was followed by the 44 066, soon followed by many hundreds of other machines with this tender.

continues on page 14





**Photo above:**  
Unit tenders 2'2' T 32 were not that rare on the German Federal Railway. Also 03 054 (Bw Köln-Deutzerfeld) is shown in April 1955 in Oberhausen Hbf. Photo: Reinhard Todt, Eisenbahnstiftung

**Photo below:**  
Even the 41 293, fitted with new-build boilers, ran with a riveted tender of the 2'2' T 32 type, as recorded on 1 June 1968. Although all Class 41 production engines were originally supplied with the 2'2' T 34, they soon had to give it up in exchange to Classes 01 and 03. Photo: Wolfgang Bügel, Eisenbahnstiftung



In the peacetime version it can be recognised by the openwork coal box struts, in wartime deliveries the struts were without the cut-out. The front boards were now also standard. The Reichsbahn, on the other hand, soon abandoned the sliding axle bearings and opted for roller axle bearings.

A decisive reason for this was that this tender, because of its large water supply, was soon coupled with the 01 and 44 series, for whose large boilers it was the first choice. They ensured extensive freedom from maintenance and lower running resistance.



Also, because the unit tenders 2'2' T 34 were almost universally equipped with roller axle bearings, the Reichsbahn liked to provide them with the express steam locomotives, because this finally eliminated the danger of hot running during high-speed runs. 01 066, seen here in Göppingen during Märklin Days 2023, also owes its existence to these circumstances.

With the class 01 parade locomotive, it was also more suitable from a running point of view, as the maximum permissible speed of the more recent deliveries had been raised to 130 km/h. In the course of the war, the Reichsbahn converted both the first deliveries of this tender and the 2'2' T 32 accordingly.

## The conversion project

NoBa-Modelle's tender body fits very well overall with the Märklin running gear, which can easily be removed from a 2'2' T 34. In view of already 51 years of production, it is easy to get hold of a donor model on the second-hand market.

The fact that we do not simply use the bogies of the small series manufacturer is due to the fact that these are designed for the in-house magnetic coupling. They therefore do not fit on a steam locomotive model and also do not open up any coupling possibilities for non-converted wagons from Märklin.

A first test reveals some need for adjustment, but this can be judged as manageable. It turns out to be just perfect that the Märklin running gear has a circular opening in the middle that is exactly aligned with the threaded sleeve in the small series body. The undercarriage and superstructure can be screwed together just as easily later as NoBa-Modelle has thought to do with its own complete model.



The first step is to glue the brass weight into the coal box. In order to be able to build a prototypical dumping cone on it, a suitable structure is built in front of it and on its surface with the help of the LED-Light Booster from Uhu.

So, our conversion begins with gluing the brass weight in the coal box. For this we use Uhu All Purpose Glue Super, which is a mixture of conventional glue and cyanoacrylate. After gluing, the weight forms the substructure of the coal insert.

In order for this to be applied credibly later, however, the pouring cone still needs to be refined somewhat. This is done with the help of the “LED Light-Booster” from Uhu, which is also suitable for filling gaps. Here, we place some of it in front of the weight in the direction of the removal point and harden this by means of UV light.

If we work our way forward layer by layer, nothing will flow, because after the light treatment the mass is crystal clear and hard. We also apply some of it to the top. In this way we gradually remove the appearance of a rectangular block. The cured UV adhesive is paintable and needs no further treatment for the following steps.

continues on page 17



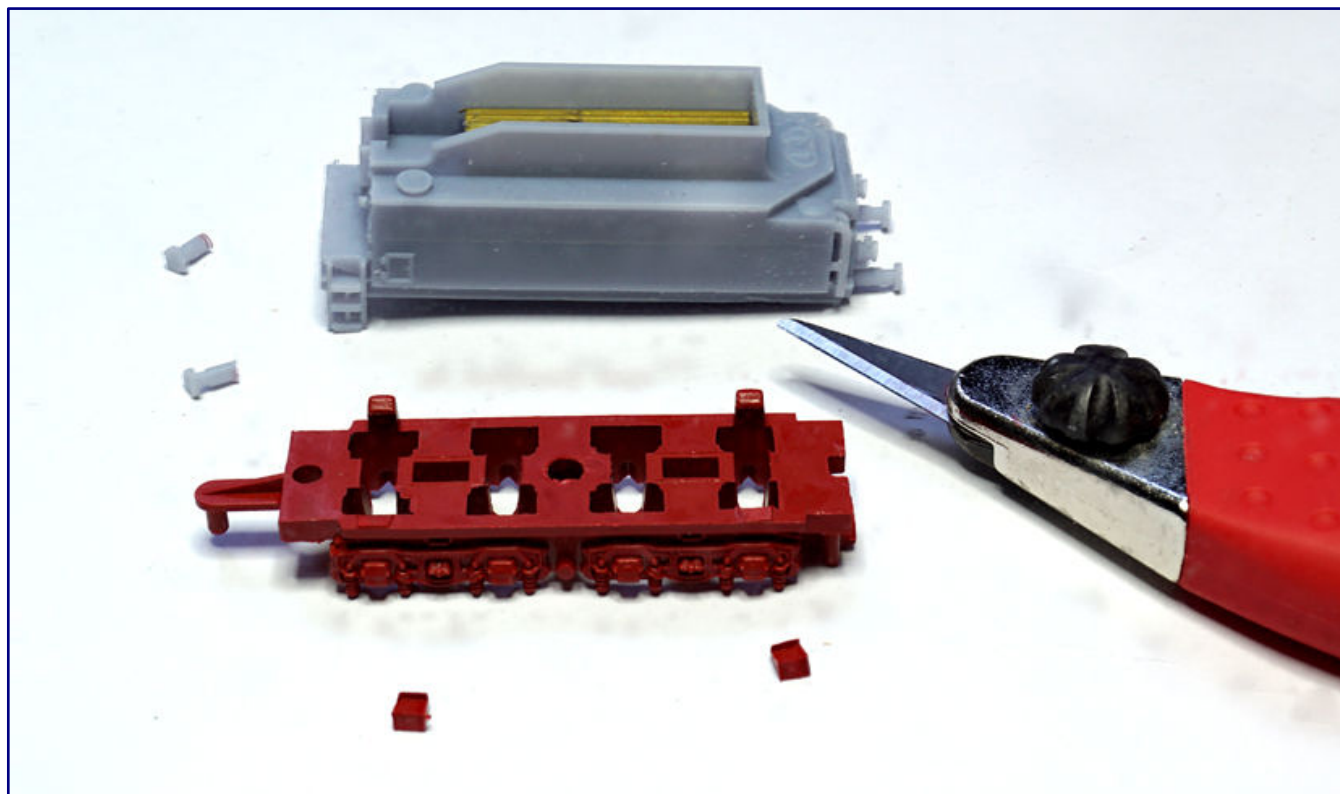

**Photo above:**  
The catches on the running gear for the weight used by Märklin have to give way, as well as the front buffers on the 3D printed housing are removed. The working surface of the heater must also be shortened a little with the file.

**Photo below:**  
Some material also has to be removed from the side so that the tender undercarriage is aligned with the new housing. The standard rail clearers on the undercarriage have already been dismantled.



Now it's time to adapt the running gear and the superstructure so that both parts can be connected without any problems. The front buffers have to be removed from the body of the tender, because the prototype only had these when it was converted into a service freight car. On the locomotive side it originally had butt plates as well as main and auxiliary coupling irons, which represented a close coupling.

On the Märklin undercarriage, we cut off the four retaining lugs at the top with a sharp tinkering knife, which are intended to hold a weight with this manufacturer. The long sides also require material removal with the file until the undercarriage fits into the new superstructure.

Too much of a good thing are also the round replicas of the track clearers at the rear end, while the system coupling shaft can remain, as it does not interfere and will have to accommodate the coupling again later – it just cannot then accommodate a fusible pin from the earlier superstructure. This will therefore have to be replaced, as well as the track spaces that find their support on the underside of the superstructure.

As soon as this adjustment work is finished, we put the two parts together provisionally, reinsert the four axles and do a positioning test with a suitable steam locomotive. The intermediate result proves to be good, but the tender cannot swing out freely in curves. This changes when we grind back the tread for the staff a little. Repeated tests show when enough material has been removed.



Evergreen round bars are used to create new track scrapers, which are mounted directly on the tender box. A rectangular profile for the coupling guide in the shaft is already prepared and only needs to be sanded. After painting, the final assembly and shortening of the track scrapers can take place.

Then the new construction of track clearers takes place. For this we use a round bar made of polystyrene with a diameter of 1 mm (Evergreen, art. no. 500211; distributed by Faller). In the longitudinal line of the wheel treads and buffers we create the necessary receptacles at the tender end behind the buffer plank. An HSS twist drill in the pin block helps us to do this.

We cut the round rod generously so that we can shorten it to the correct size later. Since we now have the quiver with our PS profiles at hand anyway, we immediately look for a suitable rod to hold the coupling guide, the piece of which we first cut off just as generously.

A square profile with an edge length of 1.5 mm each (Evergreen 500153) is suitable. It fits unmachined but not yet into the opening of the coupling shaft, because one side has to be sanded oval first, so that the coupling body can turn in the curve later. Prepared accordingly, we put this part aside for the very last step on our tender.

## Fine tuning?

What follows can certainly not be described as fine work, but it is decisive for the overall appearance in a special way. Our attachment parts are still lacking colour, as is the 3D printed superstructure. The latter gets a deep black overall appearance with the injection pen (RAL 9005).

For this we use a PU primer ("Black Primer" SNR-403) from Badger, which also produces the final Photo here. After drying, we paint the rail edges with a brush in satin fire red (Oesling Modellbau 81003000).

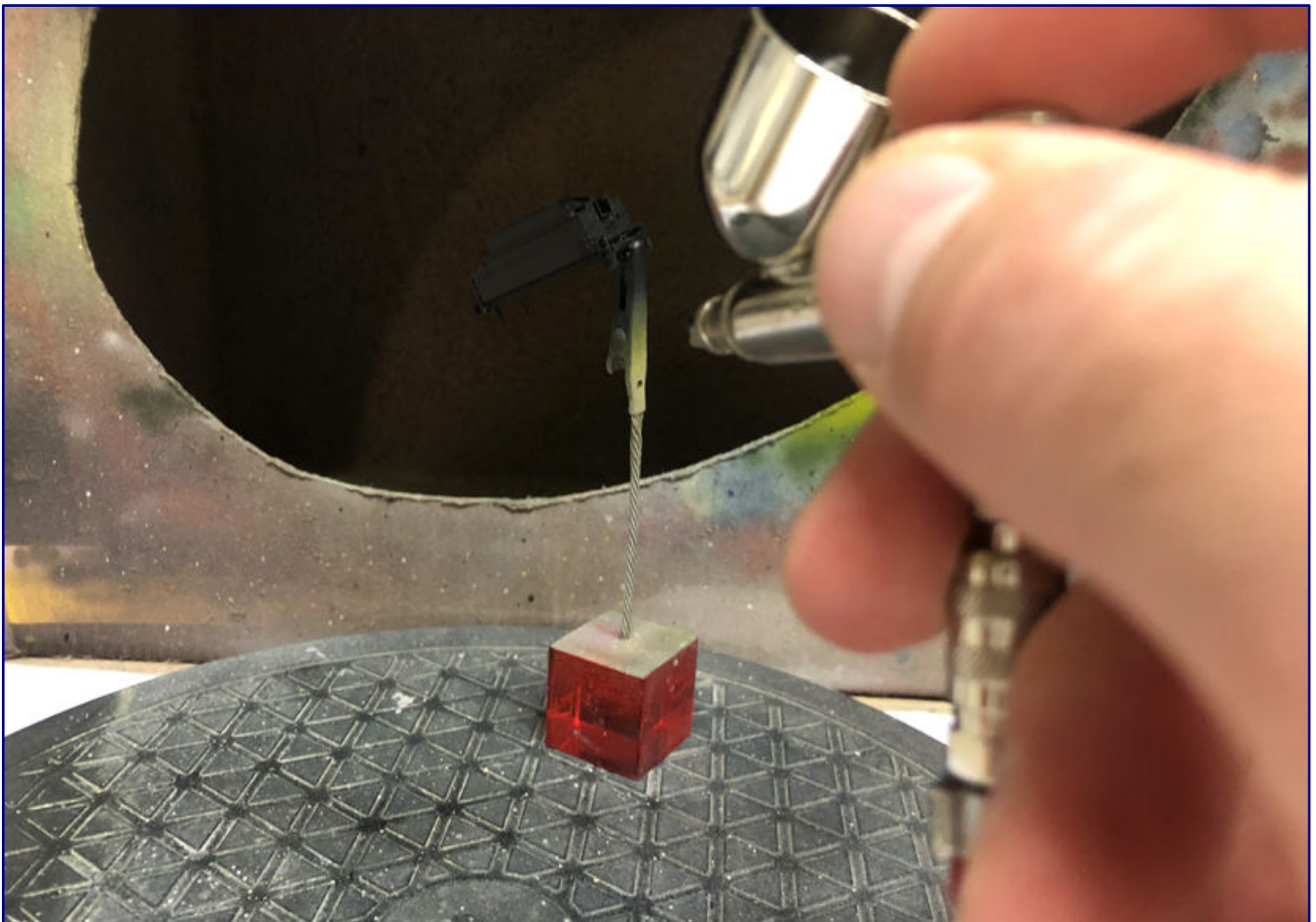

We already achieve the black colour of the tender superstructure with a primer that is applied by spraying. We use "Black Primer" (art. no. SNR-403) from Badger.

If you wish – we have refrained from doing this for the time being – you can now apply wet decals with new tender inscriptions that you have created yourself or that have been printed by one of the relevant suppliers. The same applies to the operating number of the intended locomotive, which can also be selected by printing or as an etched plate, depending on the time depicted.

In our case, it has not yet been decided which series the converted tender will be permanently coupled to. The final step in the colouring process is the clear varnish sealing, for which we recommend the products from Bergswerk.

The degree of gloss should also be adjusted to the locomotive model, which can vary greatly depending on the article number and year of production at Märklin. Consequently, this is also a step that remains open for the time being in our conversion.

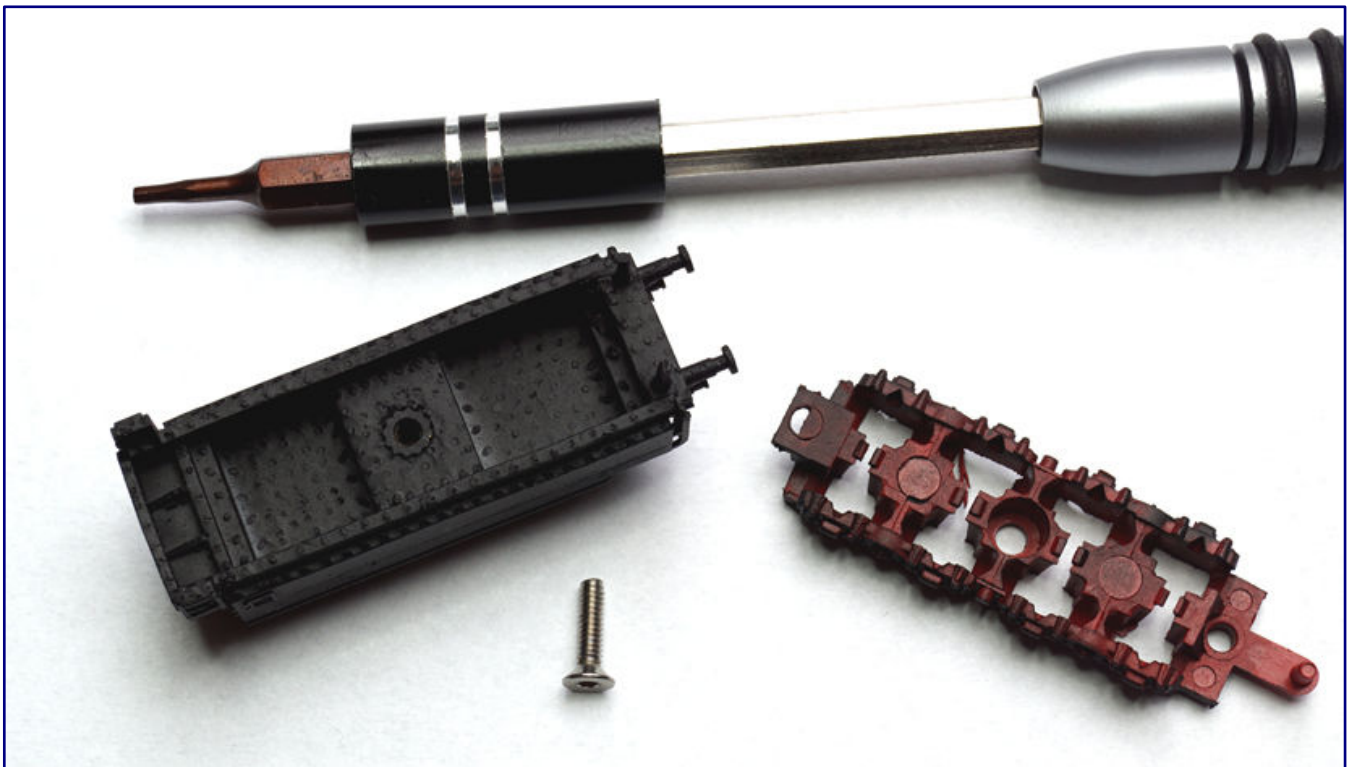

After the described work, the small series superstructure and the Märklin chassis fit together well. Thanks to the opening in the chassis, the screw connection from NoBa-Modelle can be used for a permanent hold.

There are also several alternatives for the running wheels of the tender: light or black nickel-plated disc wheels, also matched to the locomotive model in front. The prototypes had spoked wheels, which are also available in the Märklin assortment, but unfortunately have a high price and are hardly available second-hand.

Because there is little to see of them in the chassis, there is definitely an option to continue using existing disc wheels and modify them a little. To do this, take a piece of polystyrene plate, drill a hole in the diameter of the wheel tread and use it as a template for spray painting.

Since the Oesling lacquer (and also alternative products) have little hold on metal, a suitable primer is indicated. A solvent-based primer is the first choice here. In the Weinert range you will find such a primer as nitro-acrylic metal primer (2698). After all solvent residues have dried and evaporated, we can continue working with the red Oesling lacquer.





To help our readers understand the constructional differences to the Märklin tender, this top view should help with the comparison. You can also see how the dump cone above the brass weight could be reproduced: In the prototype, the rear bottom of the coal box was horizontal, only the front one had a slope that hindered the sliding of the coal and was not very popular with the personnel because the stoker sometimes had to crawl there.

At the modeler's request, the undercarriage gains even more depth if it is also painted black and the protruding surfaces are then again highlighted in red with a fine brush-over. At the same time this creates the impression of light dirt, because a steam locomotive undercarriage does not stay clean for long.

At the end of these finishing touches, we put real coal in the tender's box superstructure. As with the crane in the last issue, it comes from Jeweha Modelbouw in extra fine grain. This Belgian supplier has various distribution partners, but is mainly present in person at larger trade fairs.

Now the chassis and superstructure can be connected with the screw included in the NoBa model kits and we are approaching the final step. Now only the clutch and the pressure spring have to be inserted into the shaft and fixed with our PS profile piece.

To prevent it from falling out, we fix it to the bottom of the coupling shaft with a drop of glue. This should be thick so that it does not run into the interior and stick to the entire coupling.

The result of our little tinkering is a unit tender from DRG times, which looks considerably better than the Märklin fossil and at the same time offers a welcome change behind some unit machines.

Again, we can transfer a piece of railway history to the small scale in an individual way. Who knows when the large-scale manufacturer will recognise the potential here and expand its mould construction kit for steam locomotives?



Inspired by the prototype photo on page 6, we have had a class 03 steam locomotive pull up with an express train for a photo session. This scene, which was not uncommon in DRG times, can still be depicted after 1945: Some express locomotives that did not have this tender coupled ex-works even received it later, as can be seen from pictorial evidence in the literature.

**Manufacturer of the donor models:**

- <https://www.maerklin.de>
- <https://www.noba-modelle.de>

**Working materials and tools:**

- <https://www.bergswerk.de>
- <https://www.faller.de>
- <https://www.oesling-modellbau.com>
- <http://www.peter-post-werkzeuge.de>
- <https://www.uhu.de>
- <https://weinert-modellbau.de>



# *Ihre Film- und Fotosammlung braucht einen sicheren Hort!*

## **Unsere Aufgaben:**

Film-/Fotosammlungen:

- **bewahren**
- **auswerten**
- **veröffentlichen**

Eisenbahnprojekte:

- **fördern**
- **initiiieren**

## **Unsere Garantien:**

- + **personenunabhängig**
- + **sicher**
- + **gemeinnützig**
- + **steuerlich privilegiert**

*Sie möchten  
eine Sammlung der  
Nachwelt erhalten?*

**0151/573 96 21 1**

*Rufen Sie uns einfach an!*

*Sie möchten unsere  
Arbeit unterstützen?*

**Bilderkonto:**

**Stadtparkasse Solingen  
DE73 3425 0000 0001 3362 47**

**EISENBAHNSTIFTUNG**

JOACHIM SCHMIDT



[www.eisenbahnstiftung.de](http://www.eisenbahnstiftung.de)



Build your own structures (part 4)

## Up to the Water Tank

*In Part 3 of this series, Jochen Brüggemann described the preliminary calculations and drawings for a precise construction of his water tower, before he then turned to the most difficult construction stage with the conical base. Today, we continue step by step upwards until the finished model, based on the Ottbergen original, is standing in front of us.*

By Jochen Brüggemann. In the last episode I described the construction of the truncated cone for the base of the water tower. The other elements will follow in this fourth part, but their construction is not the end of the story. The already finished part as well as the other parts have “flaws” that should not be noticeable. I also had to consider this.

Since all the components in the shapes of a truncated cone, a barrel or a cone would not be seamless to make, the plan from the very start was to align all these components during assembly so that their seams lay in a vertical line.



Today, the water tower is growing upwards according to the Ottbergen model, until it looks like this picture and is ready to decorate the layout.

I carried out all further steps in such a way that this seam line came to lie with a slight lateral offset on the later rear side of the tower, which would not be visible to the viewer.

In the prototype, the entry door and the windows of all floors were arranged in four vertical rows, each offset by 90°. To simplify matters, I only considered the row above the entrance door and an adjacent row of windows.

The wall areas of the designated window and door rows as well as the opposite ones were reinforced on the inside with suitably pre-bent PS pieces (PS = polystyrene) that reached just below the upper edge of the tower base. This reduced the risk of fracture when making the window and door openings.



In the fitting check of the tower base and top, we get a view of the back with the seam lines aligned vertically as mentioned in the report.

I also made two round plates from plain PS material to support the circular shape. To do this, I scratched circles of the right sizes with a pair of dividers that can be fixed at a desired radius.

The diameters of these stabilising plates were chosen so that one plate formed exactly a base cap (flush with the bottom edge of the wall), while the other could be positioned just below the top edge of the truncated cone. I matched both plates to the glue tab of the seam and provided them with a central opening for better handling. Then they were inserted but not glued yet.

The lower edge of the tower base I sanded on fine sandpaper. A check measurement with a calliper gauge showed that the outer diameter of the base at its upper edge corresponded almost exactly to the dimension provided in the side plan (see drawings and preliminary calculations in part 3).

For the cylindrical upper part of the tower, I determined the measurements for the height  $H$  and the diameter  $D_t$  from the side view. For both tower parts to fit on top of each other later, the diameter had to be reduced again by twice the material thickness (1.5 mm) of the PS brick embossing plate.

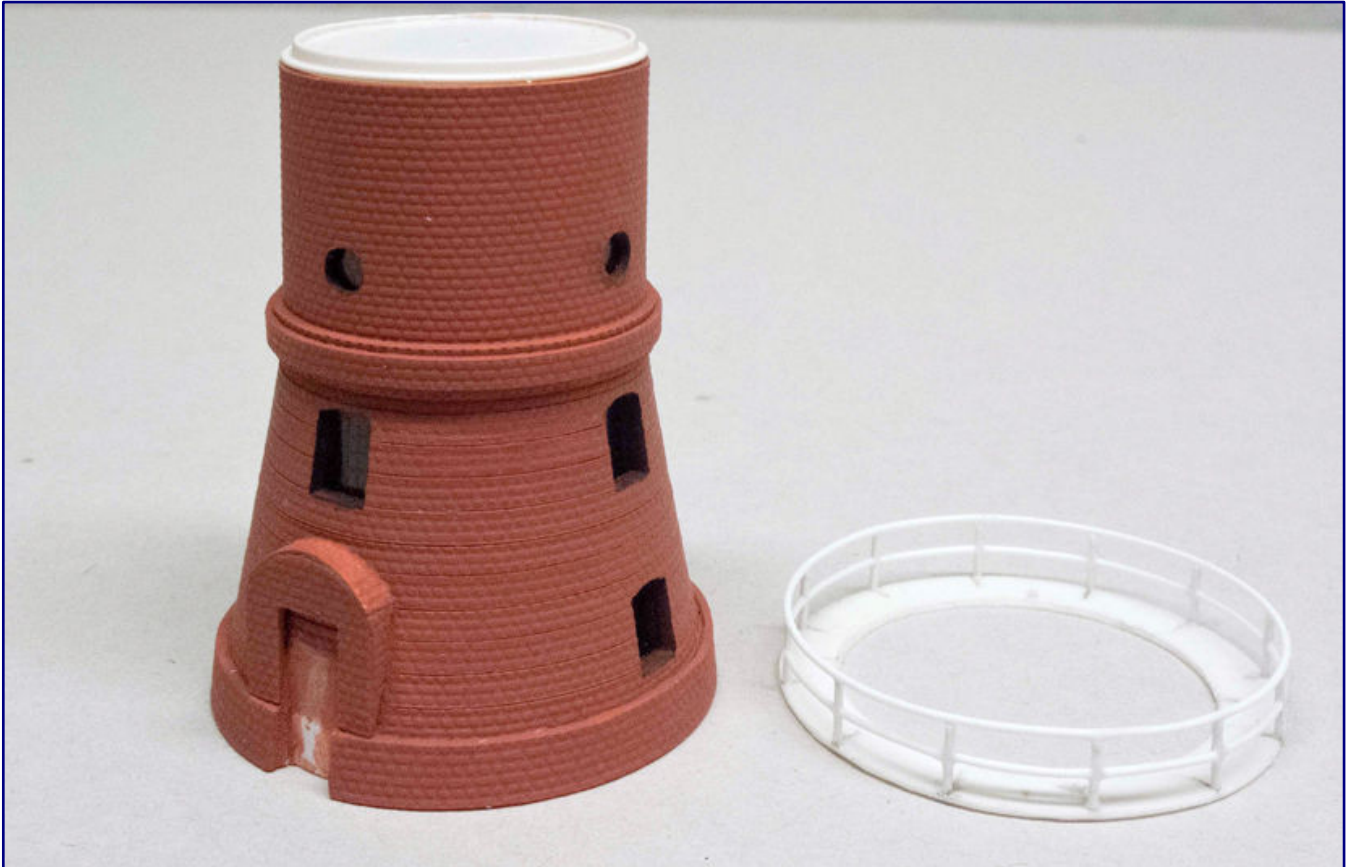

The cover plate resting on the top of the tower was later discarded. The pre-assembled circular platform (right) has been prepared and is waiting to be installed. It was to be placed above the row of round windows.

With this measurement I calculated the required circumference  $U$  of the tower top. Considering the alignment of the brick layers, I applied the measurements  $H$  and  $U$  to a PS brick masonry embossing plate, cut it out with a sharp scalpel and rolled it into a cylinder.

I pre-bent a suitable piece of plate as a glue strap and glued half of it to the inside of the wall seam with finely dosed thin-bodied plastic glue. After the glue had dried, I coated the other half of the lug with glue in the same way and carefully closed the seam, making sure that the brick wall joints fitted exactly.

As with the pedestal, I also made two circular stabilising plates for the upper part, with a central opening and recess for the seam glue strap. These plates were also initially only inserted in their intended positions (just above the lower edge or just below the upper edge of the part), but not yet glued. A check showed that now the upper part of the tower fitted exactly on the lower part of the tower.

The Ottbergen water tower was reinforced with several layers of bricks in the transition from the conical lower to the cylindrical upper part. I also copied this brick ring in a simplified form. To do this, I cut two strips out of a brick plate: one with three and one with five brick layers, a few millimetres longer than the circumference of the upper part of the tower.



First, I bent the wider of the two strips into a ring, put it around the bottom of the top of the tower and adjusted its length. Spreading a thin layer of plastic glue on the back, I glued this strip in the shape of a ring like a cuff to the bottom of the outside of the cylinder, starting at the seam, so that the lower half of the ring extended evenly over the bottom edge of the tower part.

While the glue was drying, the ring was secured in its correct position with plastic clips. Then I bent the narrower brick strip in the same way, adjusted its length as well and glued it in the middle of the wider strip so that a layer of brick remained visible all around the top and bottom of the wider strip.

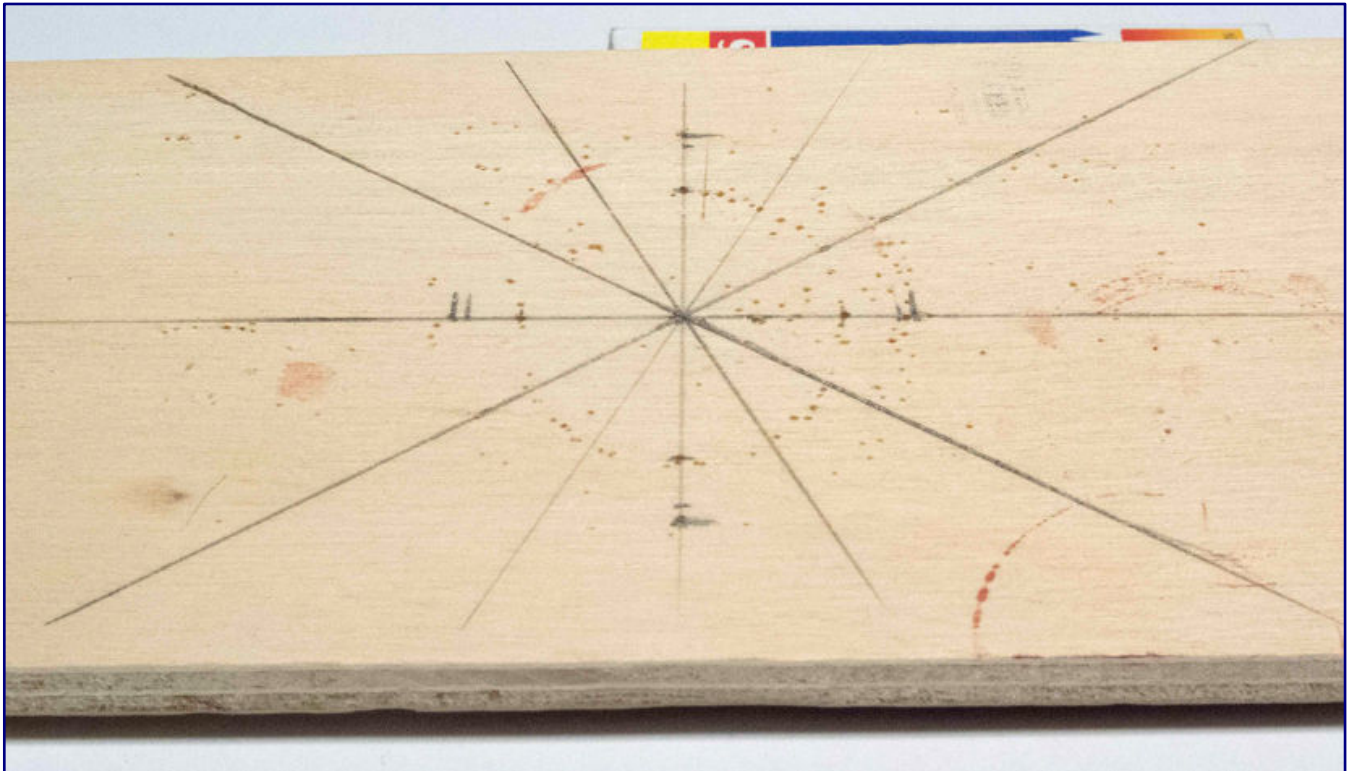

This assembly board with guiding lines is used to determine the positions for the twelve circular railing supports as well as the drill holes for the four actual load-bearing replicas.

After drying, I fixed the lower of the two stabilising plates at the intended place of the tower top with glue and expanded the lower edge of the ring slightly conical with fine sandpaper, so that afterwards the tower top came to stand evenly on the substructure.

## Door and windows

In the next step, I marked the positions of the entry door and the windows on both tower parts with a soft pencil. For the windows in the conical base, which were rounded at the lintel, I drilled small holes with a mini drill and inserted conical cutter, which I widened with a file and scalpel and brought into the intended window niche shape.

These, I then lined on the inside of the wall with thin polystyrene strips, which I sanded vertically upwards with file and sandpaper until a vertical window position was achieved. For the circular rosette windows in



This oblique view of the tower with the water tank removed allows a view of two of the four supporting struts (see arrow markings). The windowpanes with the drawn frame are also partially visible.

the upper part of the tower I drilled small holes with the cone cutter, which I then gradually enlarged with larger drills to the intended diameter of 2.5 mm. This was followed by a window outline on paper.

The bottom part inside the entrance door area was reinforced with several layers of PS boards. On the outside I marked the position of the entrance door and engraved and sanded with scalpel and file a flat, vertical surface in the door format, because the entrance door had to stand vertically and was not supposed to protrude over the reinforced tower foundation.

The entrance porch of the model got made from several wall panel sections. This created the rounded front at the top (with the actual door opening), two sides tapered at the bottom (so that the front became vertical) and a rounded cover made of brick panel.

After assembling and mounting, I painted both wall elements of the water tower and also the window niches with slightly diluted acrylic paint. Afterwards I covered the niches with a non-opaque anthracite glaze.

With the help of the window outline I drew the window frame edges and the glazing bars according to the method described in the excursus of part 2 (see **Trainini®** 1/2023). In this case, black pigment ink was used. The installation also followed the pattern familiar to readers.

A rectangular piece in the shape and size of the entrance door was cut from a very thin scrap of board, painted it medium grey and glued it into the prepared tower entrance. This marked another milestone in my building project.



I continued with the circular stabilising plates in the base, which were now permanently fixed with plastic glue. Beforehand, I had widened the central opening in the base plate to an octagonal shape and made a matching octagonal “negative” out of cardboard, which would later serve as a placeholder when positioning it on the layout. A centre line with an arrow marks the position of the entrance door.

In the next step, I determined the outer diameter of the circular platform from my side plan. I measured the inner radius for the circular platform so that after assembly a gap of about 0.5 mm would remain between the tower wall and the circular platform.



The door leading into the base was created in the manner described in the article. We have already explained the design of the windows in a previous article.

each and were not allowed to be exactly above a window but were offset 15° laterally from their vertical centre.

The ring-shaped platform I drew on a 0.5 mm thick PS plate and cut it out with a pair of dividers. For the railing, a mark for a railing support was made every 30° along the outer edge of the platform. The railing was made of 0.5 mm thick round profile.

From a round profile bar, I cut 12 supports to fix them at marked positions on the outer rim of the platform with plastic glue. I used the same material to make a ring with the same outer diameter as a handrail, which I glued to the top of the supports.

The handrail railing at half the height of the handrail was made of slightly bent round profile pieces cut to length and glued between two handrail supports.

A small rectangular recess the same width as the access door was made on the inside edge of the platform at the point that would later be opposite the access door.

Finally completed, it was to be held up by 12 simplified rests underneath the railing supports. Four of them should actually have a load-bearing function, the other eight are only dummies.

The load-bearing parts were made from 0.5 mm thick pins, for which I drilled precisely fitting holes in the walls of the upper part of the tower. These holes had to be offset by 90°

Then I applied plastic glue to the lower edge of the outer wall of the upper part of the tower, inside the sleeve, and placed it on the pedestal, checked its position and alignment and pressed it on.

Finally, I covered the brick walls of the entire tower with the charcoal glaze. In the upper part I now also fixed the upper circular stabilising plate with glue. The upper edge of the tower and the edge area of the upper stabilising plate were then given a covering charcoal-coloured coat of paint before the work on the water tank was to follow.

## The water tank

The construction of the water tank began with the production of its lower part, which tapers downwards in the side view. I used a smooth 0.3 mm thick PS sheet as material. I took the dimensions for the radii  $R_1$  and  $R_2$  from the side view; the reference point here was the intersection point  $S_2$ .

Due to the low material thickness of the PS plate, I did not correct the radii  $R_1$  and  $R_2$  by the plate thickness. Using the method described above, I also calculated the angle  $\alpha$  for the desired segment.



This oblique view from the later rear side also shows the seam lines. The water tank is almost ready for mounting except for its roof.

The determined values were then transferred to the plate and the drawn ring segment was separated by scoring with a pair of dividers and cutting with a scalpel. Carefully and evenly bent into a conical shape





The water tank has also received a ventilation assembly on the roof. Without the tower pedestal, however, this component would hardly reveal its function right away.

by hand, this ring segment became a truncated cone whose seam I could glue together on the inside with a strap.

Inside, I stabilised the truncated cone at its narrower end, the later water tank base, by gluing in a precisely fitting circular plate and sanded it flat with fine sandpaper to create a level bearing seating surface.

The barrel-shaped upper part of the water tank was also made of 0.3 mm thick PS material. The diameter  $D_t$  of the upper part was measured and taken from the diameter of the lower part at its later upper edge.

From the side elevation I determined the height  $H$  of the upper part of the tank, whereby I added a small amount to consider that the upper edge of the tank would later be covered by the roof overhang.

From the 0.3 mm thick polystyrene sheet I cut out a rectangle with the dimensions  $H * U$  and carefully bent it with my hands into a barrel-shaped hollow body. I closed the seam on the inside of the shell with a glue strap.

From the panel I cut two equal, circular plates whose diameter corresponded to the inner diameter of the barrel. One of these plates I glued into the lower end of the shell to stabilise it. The other plate I put aside for the roof construction.

Originally, I wanted to fix the water tank with an angle profile on the tower. But as this would have changed the proportions of the structure to its disadvantage, I decided against it and placed it directly on the stabilising plate of the tower cylinder. A test confirmed the horizontal position of the upper edge of the water tank and the vertical course of the shell.

To finish this step, I painted the outside of the water tank with a medium grey acrylic paint and imitated with dark brown paint rust stains and rust flows in some spots. Finally, I also covered the water tank with the charcoal-coloured glaze.

## The roof as a capstone

The cone-shaped roof of the water tower was also made from the 0.3 m thick building panel. The necessary dimensions  $R_3$  (radius of the shell) and  $D_k$  (diameter of the cone bottom) could again be taken from the side plan.

This enabled me to calculate the circumference of the cone's surface  $U_3$  and the circumference of the cone at the lower edge  $U_k$  and then also to determine the angle  $\alpha$  of the desired circular segment.



**This is how the water tower looks after the assembly of the water tank. Other parts are still missing.**



Since the edge of the roof was not to be flush with the upper edge of the water tank, but had to protrude evenly, an overhang of 2 mm had to be added to the shell radius R3 when drawing the circle on the PS plate. The angle  $\alpha$  was also drawn into the circle.

Again, I scribed out the surface with a recess compass and drilled a hole exactly in the centre with a 1 mm thin drill bit, which made it possible to reduce unwanted stresses and cracks later when bending the cone shell.

Then I cut out the wedge-shaped segment ( $360^\circ - \alpha$ ) on the drawn lines with a sharp scalpel. I shaped the remaining part of the circle into a cone and fixed the seam with a glue strap, leaving the later roof overhang free. Here the seam was only closed with glue.



On the finished water tower, which had also already received its patina, the door on the platform can also be seen from this viewpoint, from which the maintenance staff exited after using the stairwell in the base.

A small central hole was drilled in the previously prefabricated circular plate (from the previous step in the construction of the water tank). Then I glued it into the roof construction from below to stabilise it so that the roof overlapped evenly. The test on the water tank revealed that the roof was lying straight.

Next, using 1.0 mm wide Evergreen profiles with a semicircular cross-section. I pre-bent a circular piece on a cutting plate, so it was slightly longer than the circumference of the roof. Finally, I glued it on as a gutter, starting at the seam.

Before fixing its end, I shortened the profile to the appropriate length so that a flush gluing was possible. Finally, the roof and the round side of the gutter got a coat of black and dark grey acrylic paint, respectively.

I simplified the ventilation construction on the conical roof a bit compared to the prototype. I took the height and the diameter of the octagonal structure from my side plan. On a 0.3 mm thick piece of board, I drew a strip, the width of which corresponded to the height of the superstructure without the roof.

Then I carefully carved parallel stripes into this strip with a scalpel to indicate the slats. I handled the diameter of the superstructure as if it were the diameter of a circle, calculated the circumference of the circle and divided it by 8. I rounded off the result to half a millimetre and used it as the width of a single side surface of the superstructure.

At the distance thus determined, I scored the strip vertically, cut it out and shortened it to the total length of the eight side faces. The vertical scores were my kinks for the octagon, which was closed at the seam with plastic glue.

For the roof, I scribed a circle with a pair of dividers of the same material, with a slightly larger diameter than the octagon of the tower bonnet. In the centre of the circle, I drilled a hole with the diameter of a pin and squeezed the surface of the circle to form a flat cone.

A wooden block with a hole smaller than the diameter of the circle and a slightly conical brush handle served as stamp to apply pressure. I stuck a suitable pinpoint into the formed cone from below, secured it with some plastic glue and glued the roof onto the ventilation unit. After drying, I mounted the ventilation unit on the roof of the water tank. Now the ventilation unit got a coat of black acrylic paint as well.

## Setting up platform and roof access ladder

The next step was to assemble the circular platform. Into each of the pre-drilled holes in the top of the tower I inserted a pin cut to length so that they protruded horizontally and at exactly the same distance (4.5 mm) on the outside and secured them with plastic glue on the inside of the tower.

From a 0.5 mm thick round profile bar I cut eight dummy pieces of the same length (4.5 mm). I coated the protruding ends of the pins with plastic glue and placed the finished circular platform on it from above.



From this perspective, other parts described in the construction report can be seen: the downpipe, the access ladder to the roof and the water level indicator.



I aligned it so that the seam of the railing faced backwards (the direction of the seams of all tower parts), the gap between tower and circular platform was even everywhere and each of the pins came to rest exactly under a railing post.

After the glue had dried, I turned the tower upside down and reinforced the four glued joints with super glue. After this had also set, I glued the round profile pieces that don't carry weight with plastic glue to the underside of the circular platform, with one end touching the tower wall and the other end pointing towards a railing post. Finally, the complete circular platform with railing and supports also received a dark grey acrylic coating.

From a very thin piece of leftover panel, I made a small door that closes the access from the upper part of the tower to the circular platform. It was painted in medium grey and glued to the outside of the tower, opposite the recess in the circular platform. From the small remainder of an etched ladder, I formed an access ladder, which I glued as a connection from the lower edge of the access door to the recess in the circular platform.



The water tower is located on the layout and has been integrated into its surroundings.

Next, I coated the bottom of the water tank with Noch grass glue and glued it, again with the seam side facing backwards, to the centre of the stabilising plate of the upper part of the tower.

In the original, a ladder made it possible to climb from the circular platform up to the roof of the water tank. This ladder was supported by two metal rails arranged in a ring. The upper rail was attached to the water tank below the roof, the lower rail to the upper part of the tower at the height of the circular platform. In this manner the ladder could be rotated almost all around the water tank.

In a simplified way, I made the ladder out of 0.5 mm wire scraps and an etched ladder by making the lateral supporting elements out of wire and fixing the ladder in between with superglue. The finished ladder was attached to the tower with BUSCH grass glue.

From the gutter a downpipe ran vertically along the water tank, which then disappeared diagonally at the top of the tower through the outer wall into the interior of the tower. I copied this with a 0.5 mm thick round profile, painted it dark grey and placed it according to the original.

The water tower in Ottbergen had, as usual in the steam locomotive era, a water level indicator that could be read from the outside. This was controlled by a float on the water surface, which was connected to the indicator via a rope through a small opening in the roof and via several guide rollers. This allowed it to move vertically in front of the large scale.

Unfortunately, a scale reproduction of this rope guide would have turned out too clumsy, which is why I refrained from doing so. Therefore, I limited myself to the eye-catching display scale. From glossy photo printing paper, I cut out a long rectangular piece and drew in the scale and the horizontal pointer with a very fine pigment ink pen. After painting the back in medium grey, it was attached to the railing of the circular platform.

This completed the work on the model. Before placing it on the layout, I glued the placeholder in its intended position with white glue. To do this, I aligned the octagonal piece of cardboard with the help of its centre line and pointer so that the tower entrance later pointed in the desired direction.



The eyes wander over the likewise self-built locomotive administration, the water crane and coal barn to the water tower as the highest building of the depot. This part of the layout appears harmonious and coherent, which is largely influenced by the matching buildings.

After designing the surroundings, I put a few drops of NOCH grass glue to the underside of the base plate, lowered the water tower from above onto the placeholder, looked for the right position by turning it slightly, and then pressed the tower on lightly. Since then, it has performed its role in the depot to my complete satisfaction.

All Photos: Jochen Brüggemann

Material supply sources:  
<https://www.faller.de>  
<https://www.noch.de>





# Faszination Modellbau

**3. – 5. NOVEMBER 2023**

Internationale Leitmesse für Modellbahnen und Modellbau

## MESSE FRIEDRICHSHAFEN

Zeitgleich mit den Kult-Events!

Flug-, Schiff- und Truckmodellbau, RC-Cars, Dampfmaschinen,  
Eisenbahnen & die faszinierende Welt der LEGO Fan-Ausstellung.



&



FAN-AUSSTELLUNG

Öffnungszeiten: Fr. und Sa. 9.00–18.00 Uhr, So. 9.00–17.00 Uhr

[WWW.FASZINATION-MODELLBAU.DE](http://WWW.FASZINATION-MODELLBAU.DE)

[faszination.modellbau](https://www.facebook.com/faszination.modellbau)
[faszination.modellbau](https://www.instagram.com/faszination.modellbau)
[FaszinationModellbau](https://www.youtube.com/FaszinationModellbau)



Note for English readers: The literature section that follows is not translated into English because the original texts of the books involved are in the German language. The original German is left here for information purposes only.

## Die Geschichte der preußischen G 10 **Leistungsfähiges Leichtgewicht**

**Die G 10 war dem leichten Oberbau vieler Länderbahnstrecken geschuldet. Überall, wo die G-8-Reihe zu schwer für einen Einsatz war, bedurfte es der fünfachsigen Schwester. Preußisch sparsam und wirtschaftlich konzipiert, erreichte diese Baureihe ein beachtliches Alter und war schließlich auch auf Nebenstrecken anzutreffen. Der EK-Verlag spürt ihr (mit zwei Bänden) nach.**

Hans-Jürgen Wenzel  
Die Baureihe 57<sup>10-35</sup>  
Band 1: Entstehung, Technik, Einsätze bis 1945

EK-Verlag GmbH  
Freiburg 2022

Gebundenes Buch  
Format 21,0 x 29,7 cm  
272 Seiten mit 410 S/W-Abbildungen

ISBN 978-3-8446-6036-4  
Best.-Nr. 6036  
Preis 45,00 EUR (Deutschland)

Erhältlich direkt ab Verlag  
oder im Fach- und Buchhandel

Zu einem neuen Buch der „blauen Reihe“ aus dem Hause des Eisenbahn-Kuriers, so könnte man meinen, ist nicht allzu viel zu sagen. Gewohnt hoch ist das fachliche Niveau, bislang gab es davon keine einzige Ausnahme.

Doch weit gefehlt! Zwar haben wir auch hier keinen Ausreißer gefunden, aber einfach nur ein Prädikat zu vergeben, erschien uns dann doch zu einfach. Die Inhalte dieses Titels, dessen zweiter Band vor wenigen Tagen folgte, möchten wir schon zusammenfassen und vorstellen.

Oft heißt es, lange zu warten, bis ein neu angekündigtes Buch dann endlich ausgeliefert wird und sehnsüchtig wird es dann verschlungen. Auch hier macht das Lokportrait der preußischen G 10 keine Ausnahme. Etwas aus der Reihe fällt es allenfalls dadurch, dass ihre Geschichte eben in zwei Bänden zu präsentieren ist und dafür gibt es gute Gründe, die wir noch herausarbeiten wollen.

Mit Hans-Jürgen Wenzel greift der Verlag auf einen seiner bewährten und bekannten Autoren zurück, der die Dampflok noch aus eigenem Erleben kennt und fundierter Kenner der Materie ist – gut vernetzt und mit den Archiven vertraut, die es zu durchstöbern gilt.

Alles, was das heute vorgestellte Werk, das dabei herausgekommen ist, dokumentiert und vermittelt, ist wieder einmal von einer exzellenten Bildauswahl begleitet. Die historischen Aufnahmen sind ebenso gut aufbereitet und reproduziert worden.





Bedingt durch deren Alter, nicht selten mehr als einhundert Jahre, sind sie ausnahmslos schwarz-weiß, kein einziges Farbbild konnte hier Einzug halten. Doch das ist zu verschmerzen, denn für Band 1 wurde ein harter Strich mit dem Ende des Zweiten Weltkriegs 1945 gezogen.

Die Geschichte der preußischen G 10, die ab 1925 als Baureihe 57<sup>10-35</sup> geführt worden war, begann Anfang des 20. Jahrhunderts. Erfolgreich etabliert war die Gattung G 8 in ihren unterschiedlichen Erscheinungsformen. Doch deren Achsdruck war einst längst noch nicht für alle Strecken tauglich. Die G 10 kam ebenfalls ohne Laufachsen aus, erhielt aber eine fünfte Kuppelachse, dank derer ihr Achsdruck auf 15,3 Tonnen begrenzt blieb.

Der Weg zur Konstruktion, ihre technische Beschreibung und Indienststellung sind ausführlich in der vorliegenden Lektüre dargestellt. Gebaut ab 1910, erlebte die G 10 die Wirren des Ersten und Zweiten Weltkriegs, die beide viel Einfluss auf ihre Betriebsgeschichte nehmen sollten und den ersten Band so prall mit Inhalten füllen.

Bis 1924 wurden immerhin mehr als 2.500 Exemplare von insgesamt neun Lokomotivherstellern gebaut, auch aus dem Ausland gab es Nachfrage nach dieser Konstruktion. Auch in die Fänge der Alliierten gerieten sie als Waffenstillstandslieferung, Militärtransporte brachten sie zuvor (und später im Zweiten Weltkrieg) aber zusätzlich außerhalb der Reichsgrenzen.

So waren sie beinahe in ganz Europa verstreut und bei verschiedensten Staatsbahnen im Einsatz. Der Autor spürt ihnen allen nach und konnte dafür neue Erkenntnisse und weitere Archive nutzen, die über Jahrzehnte nicht zugänglich waren.

Dieser Hinweis ist insofern wichtig, als dass es sich um eine überarbeitete und deutlich erweiterte Neuauflage eines Titels aus dem Jahr 1979 handelt. Der über vierzig Jahre alte Vorgänger ist mit diesem Buch endgültig reif fürs Altenteil.

Grund dafür sind die eingearbeiteten Informationen, die bereits genannt wurden, und den Inhalt nach Seitenzahlen glatt verdoppelten. Das war nicht gleich zu erwarten, machte das Aufteilen auf nun zwei Bände denn auch erst erforderlich.

Die aufgrund ihrer geringen Achslast, robusten Bauweise und Leistungsstärke so vielseitig einsetzbare und langlebige Dampflok hat das aber auch verdient. Sie ist bis heute bekannt und auch bei Modellbahnern geschätzt – in der Spurweite Z ist sie bislang aber allenfalls über einen Eigenbau zu haben.

Die geeignete Basis lässt sich ebenfalls aus den Inhalten des Buches ableiten, denn ausführlich wird dort auch behandelt, worauf die Konstrukteure zurückgreifen konnten und aus preußischer Sparsamkeit heraus auch wollten.

Grenzen wir abschließend noch kurz den Inhalt gegen den in einer Folgeausgabe zu besprechenden Band 2 ab: Vollständig aufgelistet werden im Band 1 die in Deutschland gebauten Fahrzeuge. Die beschriebene Einsatzgeschichte umfasst die Länderbahnzeit und Ära der Deutschen Reichsbahn bis zum Ende des Zweiten Weltkriegs. Kriegseinsätze und Auslandsverbleib bis 1945 gehören freilich auch dazu.

Band 2 wird dann 1945 ansetzen und vor allem die DB und DR im Osten Deutschlands behandeln. Auch Auslandseinsätze nach 1945 sind dorthin gewandert. In Summe liegt damit ein gelungenes und ausführliches Werk vor, das für sich noch unvollkommen bleibt und Lust auf seine Fortsetzung macht. Und genau dem werden wir uns nun auch widmen!

**Publishing pages:**  
<https://www.eisenbahn-kurier.de>  
<https://www.ekshop.de>

Zweiter Teil zu DRG-Dieseltriebzügen

## Bindeglieder zu Schnelltriebwagen

*Der vor anderthalb Jahren erschienene, erste Band einer VGB-Buchreihe zu den Dieseltriebwagen der Deutschen Reichsbahn hatte uns angesprochen. Maßgeblich dafür war auch einer der beiden Autoren, der uns aus eigenem Erleben bekannt war. Mit Spannung warteten wir auf die Fortsetzung, die das Bindeglied zu den Schnelltriebwagen darstellt, mit denen die Vorkriegsentwicklung dann später abzuschließen sein wird.*

Dirk Winkler | Günther Dietz  
Verbrennungstriebwagen der Deutschen Reichsbahn  
Band 2 – Triebwagen in Leichtbauweise von 1932 bis 1945

VGB | Geramond Media GmbH  
München 2023

Gebundenes Buch  
Format 22,8 x 29,6 cm  
192 Seiten mit ca. 270 überwiegend S/W-Abbildungen

ISBN 978-3-96453-641-9  
Best.-Nr. 53641  
Preis 59,99 EUR (Deutschland)

Erhältlich direkt ab Verlag  
oder im Fach- und Buchhandel

Im Januar 2022 hatten wir Band 1 einer neuen VGB-Reihe über Verbrennungstriebwagen der Deutschen Reichsbahn vorgestellt und dies als Start für neue Standardwerke bestätigt. Inzwischen liegt auch der zweite Band vor, den wir heute besprechen möchte.

Zunächst fällt leider auf, dass das vorliegende Buch rund dreißig Seiten weniger als das erste Buch der Reihe aufweist und auch mit etwa vierzig Bildern weniger auskommen muss. Gleichzeitig ist der Preis, den der Verlag verlangt, um satte zehn Euro gestiegen.

Das möchten wir nicht als K.o.-Kriterium missverstanden wissen, aber auch nicht einfach mit „allgemeiner Preissteigerung abtun“. Für einen um 20 % gestiegenen Preis müssen Verlag und Autoren dem Käufer aber auch etwas bieten. Genau dem werden wir nun auf den Grund gehen.

In Erscheinung treten wieder dieselben beiden Autoren wie schon beim Band 1, was aber letztmalig so sein wird. Auffällig ist schon, dass sie auf dem Buchdeckel ihre Reihenfolge getauscht haben. War diese zuvor alphabetisch, so steht nun Dirk Winkler vorn.

Der Anlass dazu wird (leider) schon im Vorwort deutlich: Der auch von uns sehr geschätzte Autor und Triebwagen-Kenner Günther Dietz ist während der Arbeiten an dieser Fortsetzung kurz vor Erreichen seines 84. Lebensjahres verstorben. Von seinen tiefen Kenntnissen weit über das heimische Gebiet der Deutschen Reichsbahn in der DDR hinaus hatten auch wir uns aus anderen Publikationen und durch persönliche Hilfe bei Recherchen vor rund dreizehn Jahren persönlich überzeugen können.

Erfreulich ist, dass sein Wissen hier noch maßgeblich einfließen konnte und sicher auch im weiteren Verlauf der Buchreihe spürbar bleiben wird. Für den künftigen Alleinautor wird die Herkulesaufgabe gewiss nicht leichter. Mitgewirkt haben aber auch weitere Kenner der Materie wie Rolf Löttgers aus Siegen, denen im Vorwort gedankt wird. Und so liegt unsere Messlatte an dieses Buch sehr hoch.





Band 1 behandelte Trieb-, Bei- und Steuerwagen, die bei den Länderbahnen und der DRG bis 1930 entstanden waren. Oft hatten sie noch einen experimentellen Charakter und waren für Nebenstrecken konzipiert.

Der nun vorliegende, zweite Band knüpft nahtlos daran an, auch wenn das an der Jahreszahl 1932 nicht gleich deutlich wird. Dass dies keine zeitliche Lücke darstellt, wird am ergänzenden Hinweis zur Leichtbauweise deutlich.

Mehr und mehr verschiebt sich damit das Wesen der Fahrzeuge zu vierachsigen Drehgestellfahrzeugen für Hauptbahnen, auch wenn Zweiachser und Nebenbahnkonstruktionen weiter zu finden sind. Doch auch sie folgen zunehmend neuen Erkenntnissen und Fertigkeiten jenes Jahrzehnts bis zum Kriegsausbruch.

Wie zu erwarten, blieb das Präsentationskonzept mit historischen Fotos, abgrenzenden und erläuternden Typenskizzen und ergänzenden Abbildungen von beispielsweise Motoren sowie ergänzender Tabellen erhalten. So bedarf es keines Umgewöhnens beim Suchen und Nachschlagen in nun zwei Enzyklopädiën.

Die Bild- und Wiedergabequalität entspricht unseren Ausführungen zum ersten Teil. Was nicht perfekt ist, ist dem Alter geschuldet und historisch einfach nicht verzichtbar. So fanden auch viele zuvor unveröffentlichte Aufnahmen Eingang in dieses Werk, wofür den Autoren unser Dank gilt.

Vermisst haben wir bei den behandelten Fahrzeugen nichts, allerdings sind die Schnelltriebwagen der DRG nicht in diesem Band enthalten! Das mag ein Käufer angesichts des zeitlichen Rahmens vielleicht anders erwarten, aber die fliegenden Züge gehören technisch nicht zu den hier behandelten Fahrzeugen.

Anders sieht das bei Aussichtstriebwagen und Güterschlepptriebwagen aus, zwei Sonderbauarten, die auch schon das Eigenbauinteresse von Spur-Z-Freunden geweckt haben. Auch Schmalspurfahrzeuge sind Bestandteil dieses Werkes.

So sind nach unserer Kenntnis tatsächlich alle Typen in Wort und Bild vorgestellt, die zum Titel dieser Lektüre passen. Ein dritter Band ist damit allerdings nicht nur wahrscheinlich, sondern auch zwingend erforderlich.

Die portraitierten und beschriebenen Bauarten dokumentieren den Weg vom Nebenbahn- bis hin zum mehrteiligen Hauptbahntriebwagen, die den bereits angesprochenen „Fliegenden Zügen“ erst den Weg ebneten.

Ein weiteres, ausgesprochen spannendes Kapitel deutscher Eisenbahngeschichte ist hier Thema eines Werkes, das wir im Umfang zwar etwas größer erwartet hatten, aber dennoch keinen Wunsch offen lässt und schon gar nicht Lücken offenbart.

Insofern kommen wir zu den Überlegungen am Anfang dieser Rezension zurück: Der Preis lässt sich durchaus als happig wahrnehmen, steht aber im Verhältnis zu Quantität und vor allem Qualität des Inhalts in einem ausgewogenen Verhältnis.

Deshalb freuen wir uns, dass der Verlag die Reihe gelungen fortsetzt und sicher ebenso würdig abschließen wird. Bleiben wir gespannt, ob dies bereits mit einem dritten Band erfolgen wird oder doch noch einen vierten Teil erfordern wird.

Publishing pages:  
<https://www.vgbahn.shop>

## Black Forest Railway Museum Very small meets very big

*This year's special exhibition "Small meets big" at the Eisenbahnmuseum Schwarzwald (Black Forest Railway Museum) has been advertised in our magazine, and Trainini® was happy to join in as a supporter. We were naturally tempted, therefore, to visit Schramberg, in person, to talk to the people involved and to report back to our readers on the experience.*

Schramberg, located in the Württemberg part of the Black Forest, is not exactly a household name. And yet it has a special history, because it is home to the famous watch manufacturer Junghans, which was once the world's largest manufacturer of timepieces.

Former company buildings in the H.A.U. industrial park, that were no longer needed for production, later became the property of the municipality and now house various museums. Among them, in building 22, is the Black Forest Railway Museum, whose name can be misleading. After all, everything there revolves around model railways and not the 1:1 scale prototype.



In the the Eisenbahnmuseum Schwarzwald (Black Forest Railway Museum), (almost) everything revolves around gauge 2, and with it primarily around the complete self-made construction of locomotive and wagon models as well as their individual components. The unmistakable favourite of the active members is the DB's class V 200<sup>0</sup>.

The "Interessengemeinschaft Spur II, Regionalgruppe Süd", is the operator of the 742 m<sup>2</sup> exhibition area. The core of their exhibition is the world's largest collection of 2 Gauge models.



When it comes to this scale (1:22.5), The only commercially available narrow-gauge vehicles for this scale (1:22.5) are from the LGB brand, while no comparable products exist for standard-gauge rolling stock, at least for authentic looking ones.

Thus, the 170 metres of glass showcases comprise around 900 such self-made constructions. Each of them consists of up to 10,000 individual parts, which have also been produced in-house over several years of work. A 400 m<sup>2</sup> layout shows some of them in operation. There they make for a fascinating sight with their sheer their size and smooth running properties.



LGB is also represented in the exhibition, among others with this fanciful steam train based on Wild West themes.

The museum has been in operation for eleven years already, with the beginning of this courageous commitment (which also involves a significant financial risk for the association) dating back to 26 October 2012 - exactly 35 years to the day after the end of steam locomotive era in West Germany.

And steam traction does indeed find a worthy place in the rooms of the exhibition: we look into the former Braunschweig repair works and experience a trailing steam locomotive during supply runs in the depot. Museum director Michael Herberger emphasises that seeing trains in active operation is a key part of the museums philosophy. After all, a model railway is always about wheels in motion.

Other objects also include by the somewhat smaller "royal" gauge 1 (scale 1:32), which is manufactured industrially and is represented here, for example, by models from Kiss, KM1, and Märklin. And the latter manufacturer was then also the cue for a new experiment, which, as it turned out, has been successful.



The museum houses 170 metres of showcases which are filled to the brim with models in 1 and 2 scale. And 900 of these models were built from scratch.

Expanding to Gauge 1 allows for a comparison to the sometimes huge-looking (and usually also very heavy) models of the core exhibition. This creates the opportunity for visitors to understand and appreciate the exceptional achievement of scratch building in such a scale.

But it was the arrival of the Z gauge in the form of the Märklin Mini-Club that completed the picture. The occasion was the 50th anniversary of Z scale last year. The special exhibition that runs for a year (after which it changes again) was therefore also dedicated to it, and our magazine has been promoting it, repeatedly.

The fact that 2 gauge is almost ten times larger than 1:220 scale creates the hoped-for visual contrasts that promise even more excitement. This was made possible by two key persons: Firstly, Eckard Jehle was looking for a permanent home for his home layout, which we had presented in **Trainini®** 8/2020.

He is a native of Schramberg and our layout portrait proved to be a decisive reference, as he told us. It was through this article that he and the people in charge came into contact. In the end, the layout was moved from Karlsruhe to the Black Forest Railway Museum. Together with incoming donations of rolling stock, this provided a basis for the expansion of the museum exhibition.

On the other hand, there was still a lack of a person who is familiar and experienced with Z gauge. This person should take on the task of maintaining and, if necessary, repairing the rolling stock, but also be able to demonstrate the layout and instruct the museum staff sufficiently in its operation.





Bringing Z scale into the exhibitions is attractive because of the deliberate contrast with the large models. The differences in size as well as the advantages of both scales are thus best perceived by the visitor.

The person they were looking for was Klaus Sieber, since they had already made the acquaintance of museum director Michael Herberger. So, the basic conditions were fulfilled and nothing stood in the way of the special exhibition.

That this sounds easier in retrospect than it actually was to prepare and organize, however, becomes clear from one fact: The desired, one-year special exhibition on the 50th anniversary of the Mini Club did not begin until March 19, 2023, and thus after the end of the anniversary year. We must also not forget here that 2022 was still characterized by contact restrictions.

And, so, we are all the more pleased that everything has come to a happy conclusion and that the juxtaposition of the two extremes in model railway scales got off to a good start. To whet your appetite for your own visit, we therefore briefly summarize what will be on offer on site.

On the one hand, there are showcase presentations with selected items from 50 years of model railroad history. In the case of rolling stock, the Z-gauge models, which document progress in painting, printing, and detail reproduction, are always juxtaposed with a larger gauge, usually gauge 1.

In this way, the visitor is well aware of the advantages that distinguish the respective scale: on the one hand, uncompromising attention to detail and impressive size, on the other hand, unabridged passenger cars that line up to form equally impressive long trains.

But interesting and sometimes rarely seen accessories are also part of the museum's exhibition. These include, for example, the Fallerhof in the Upper Black Forest, which is hardly known to most readers as a miniature, from the regional television series of the same name.

However, the best advertisement for the small scale is certainly the already mentioned model railroad layout by Eckard Jehle, which has found a new home here. As the central object of the special exhibition, it demonstrates the advantages of our size particularly impressively.



**The Alpine layout by Eckard Jehle is also surrounded by 1 gauge models. With its extraordinary and impressive rock and mountain design, it is a demonstration of what would not be possible in any of the other scales on a home layout.**

Visitors entering the room of this special exhibition, will be immediately presented with the long side of the layout, i.e., its full extent. Since it is not exactly small for a private layout, it is likely to create a lasting impression on the viewer.

But that's not all, because the layout's height is also cleverly designed. The authentic look of an alpine landscape can only be achieved in 1:220 scale. In any other scale, such a layout would probably have to do with cute little hills with barren rocks that cannot really convey the crossing of the tree line.

An excellent scenic backdrop and the realistic design of the rocks and mountain peaks, garnished by a cable car that leads up from the valley and halves the distance hikers have to walk, also contribute to the success of this layout.

Of course, many structures on the layout are not quite adapted to our scale and many modelers today would resort to other kits.

But here, too, a special touch is evident: After all, the layout is about thirty years old and, despite being in near-perfect condition, is thus itself a part of the history depicted. It illustrates what was once possible and what is still possible today with some creativity and talent.

continues on page 48





Photos on pages 46 & 47:

The alpine backdrop of the layout is unique and evokes memories of mountain holidays. The builder skilfully managed to create the impression of high mountains despite the limitations of a model railroad layout, even at this scale, and to create an authentic looking illusion. And in the middle of this landscape, we see prototypically long express trains with true to scale passenger cars.







By the way, family members traveling along without an interest in model railroads will not be bored either. They, too, will be spellbound by the layout operation, which of course also includes the larger side room with tracks 2, 2m and 1. For the younger visitors, there is even a short trolley track where they can test their muscle power.

And if all this is still not enough, there is still the option to visit to the Museum of Inventions, Watches and Automobiles across the street, because these four exhibitions are part of a presentation network that can be visited on a single ticket.



Tunnels and galleries to protect against debris avalanches naturally also belong on an Alpine layout. It was designed according to the school of Bernhard Stein, which was the measure of all things in the nineties.

Things will continue to be exciting at the museum even after the end of the current special exhibition: Museum director Michael Herberger revealed to us that there is always one that changes annually. And at least the next one, in response to the extraordinarily good reception, will probably also cover Z gauge again.

So, we can't go back to business as usual either. Although we have been let in on the plans and are also deliberately keeping quiet in order to maintain the suspense, our fingers are still itching (to operate the shutter release of the camera).

So, we wait and see if all plans can be realized as thought and quickly. And when the time comes, we probably won't be able to avoid another visit. The trip to the Black Forest has been worthwhile for us without any doubt!

All information for a visit:  
<https://eisenbahnmuseum-schwarzwald.de>



# SONDERAUSSTELLUNG KLEIN TRIFFT GROSS

50 Jahre Baugröße Z, 1:220  
19. März 2023 bis 17. März 2024

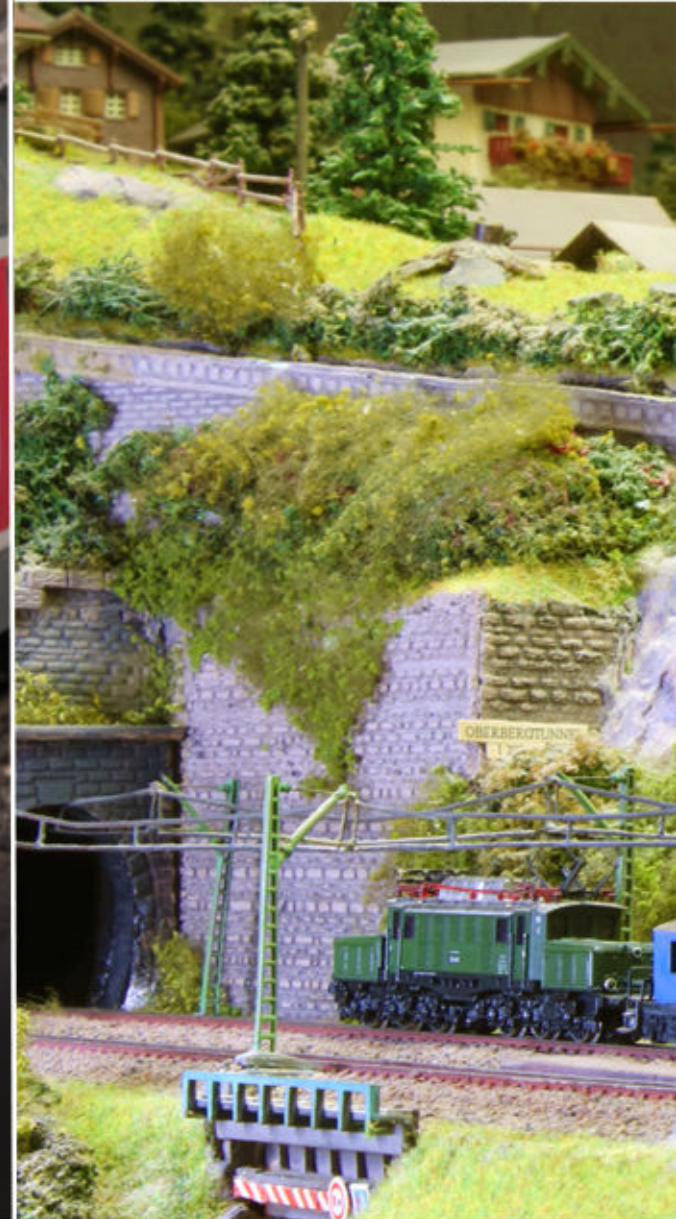

**märklin**



## Besuchsinformationen:

[www.eisenbahnmuseum-schwarzwald.de](http://www.eisenbahnmuseum-schwarzwald.de)  
Infotelefon +49 (0) 74 22 / 29 - 3 00

Gewerbepark H.A.U. 22  
78713 Schramberg





Readers' letters and messages

## Zetties and Trainini in Dialogue

*Thank you for each letter to the editor and all the feedback that reaches us. Write us (contact details are in imprint) - Trainini® lives from dialogue with you! Of course, this also applies to all suppliers in Z gauge, who would like to introduce innovations here. A representative sample is our goal. Likewise, here we note any events or meetings with significance to Z gauge reference, if we are informed in time.*



A thank you and pleasure with our report:

I would like to thank you very much for this great report about "Werdersheim". And then also a cover photo. Super.

But the other topics are also a pleasure to read. Trainini is and remains a great magazine. Many thanks.

Dirk Rohwerder, Sprockhövel

Inspired by "Railway Service and Service Freight Cars (Part 1)":

Inspired by the above-mentioned book by Stefan Carsten and Wolfgang Henn, I had the idea to realize such a mobile undercarriage shortly after purchasing and looking through the book. I got an SSym 46 and an AEG transformer from Artitec, then I started: Split the SSym undercarriage, built a suitable flatbed out of plastic.

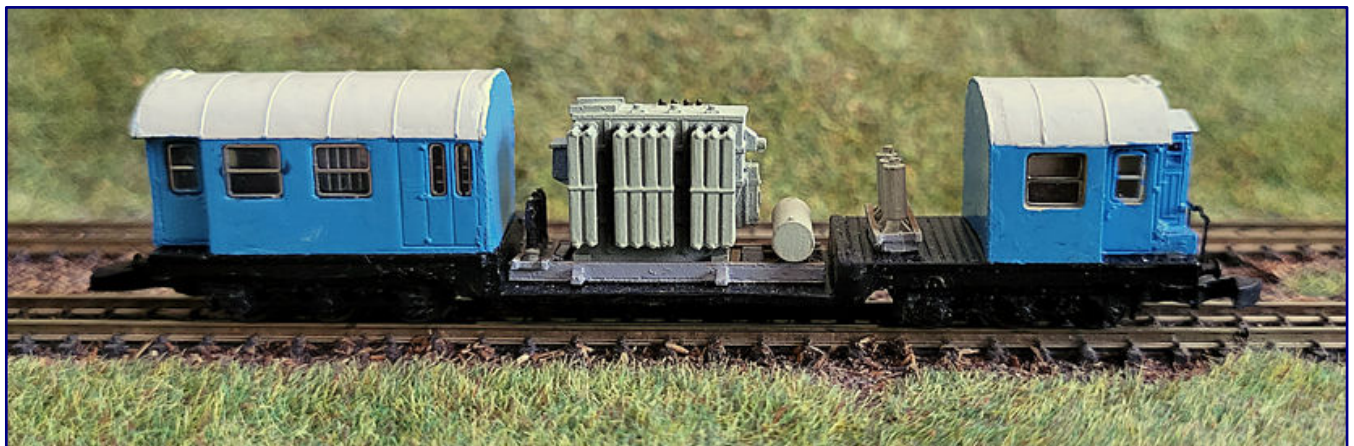

A mobile undercarriage on the basis of a low loader wagon provided the template for this self-built model of our reader. Photo: Bernd Jablonski

Housing for the superstructure was quickly found - 3-axle conversion car; housing machined, new walls created from thin plastic, the whole thing then painted in a "faded" traffic blue and mounted on the car. Test runs were successful and the car can now be used in a construction train.

Bernd Jablonski, Bochum

Free and without suitcase:

Please find attached a photo of my new layout: 80 x 56 cm. Not finished yet, motto: "It doesn't always have to be a suitcase layout."

Stephan Viragh (Hungary), by E-Mail



80 x 56 cm measures the new layout of our reader from Hungary. It was deliberately not built in a suitcase. Photo: Stephan Viragh

Editor's reply: Please keep us informed if there are any news! We are grateful for news or even a suggestion for the portrait of the finished layout.



Harald Fried is the new man on the editorial team.

#### Personnel reinforcement for Trainini®:

The editorial staff situation has been enormously strained for several months. Necessary changes in the issue planning due to delivery delays of the manufacturers lead to stronger time demands, which at the same time meet with scarce free time and a decimated group.

For the past five months, there has been a shortfall, and at times the deserved vacations of members of the editorial team could not be fully reconciled with the tasks they had to perform.

For a long time, we have been looking for a solution internally, including the entire team of editors, translators and Trainini TV, without any loss of quality. Finally, we are pleased to announce that we have found a suitable reinforcement.



Initially, on a temporary basis, Harald Fried, whose name may be familiar to some readers from the Märklin 2022 anniversary book, is supporting our editorial team and noticeably strengthening it. With this month's issue, he is taking over proofreading, and would also like to continue to look around with us and contribute wherever he can and enjoys doing so.

If it suits everyone involved, he has the option of joining the editorial team on a permanent basis, if he wishes, and contributing his knowledge and skills for our readers. From his professional life, he brings years of relevant experience from the fields of marketing and public relations.

We would like to take this opportunity to extend a warm welcome to Harald Fried and say "auf gutes Gelingen!"

#### Seasonal New Products at Noch:

"City, country, river" is the annual motto of the accessories manufacturer Noch from Wangen in Allgäu. Now, it has presented matching Seasonal New Products, which also include products for Z gauge.



The pine tree with 15 cm growth height (Item No. 20140) from the Master series is one of the seasonal new products from Wangen. Photo: Noch

The first thing that catches the eye are the trees of the Master series, a large part of which can also be used in 1:220 scale, because the vegetation in the larger gauges is reproduced almost through the series for space reasons considerably too small.

For example, we consider the ash as an extremely tall solitary tree (Item No. 20100, 20 cm), the oak (20110, 15 cm), the poplar (20130, 18 cm), pines (20140, 15 cm / 20141, 18 cm), the copper beech (20150, 15 cm), which in our view is incorrectly declared as a "copper beech", and spruces in three lengths (20190, 19 cm / 20191, 22 cm / 20192, 25 cm) to be suitable. If you have any doubts about this, you are welcome to consult the technical literature for these trees.

Then there are four new varieties of grass tufts to be added: multicoloured flocked they are in the brightly coloured variety "flowering" (06900), while in late summer they appear as "dry grass" (06910). Obviously, we looked into the bush program for the two varieties "stony" (06920 / 06921). In each of these compilations are 25 tufts with 6 mm fibre length.

Noch has now also developed its own building lighting system and offers this as the starter pack "micro-rooms LED building lighting set" (51250). This contains four different LED boards and eight interior rooms.

These "interiors" are light boxes of different sizes made of cardboard, which are folded and glued. They are then further processed similar to the Viessmann products. Also included are instructions, a diffusion foil and seven decorative sheets for designing the floors and walls.

If you need more lamps, you will find four or single LEDs (51270 / 51275) or double LEDs (51280 / 51285) per package in the light colours cool white and warm white (article numbers are listed in this order). Eight light units of these versions are also available (51271 / 51276 / 51281 / 51286).



The package "micro-rooms LED building lighting kit" (51250) contains everything needed for the new system. Photo: Noch

New LED light chains with 10 (51240), 20 (51244) or 30 (51248) light sources each have a length of 10, 20 or 30 cm and are intended as a lantern garland for festivals or as stall lighting for a Christmas market. Further ideas for use are up to the creativity of the customer.

#### Märklin deliveries since the last issue:

Märklin delivered the "compartment car" car pack (Item No. 87565) during the reporting period. This now supplements the baggage car of Prussian origin (87566) that has already been available since July. For the first time since 2005, the four-axle compartment cars with DB markings (Era III) found their way back into the program.

The main difference between these cars and the earlier model is that the Bundesbahn inscriptions do not have an Ege cookie imprinted on them. This is the only thing that corresponds to the historical prototype, because the cars with wooden bodies were no longer allowed to be used in passenger trains after 1962 at the latest.

Their early retirement was thus already a foregone conclusion, which is why the DB decided not to affix its logo (as it did with other types and series). In contrast to their three-axle siblings, the long compartment cars disappeared from the rails much earlier and supplied parts for the young German Federal Railroad's conversion car program.



In addition to the now missing Ege cookie, the new compartment cars are especially impressive with their fine printing and frame embossing, here the 1st/2nd class car AB4 pr 04 (from item no. 87655).



So, almost 20 years after its first edition, Märklin is now showing the courage to consistently follow the historical templates and to trust in sufficient prototype knowledge of its customers.

The car set consists of one example of the type AB4 pr 04 with 1st/2nd class and brakeman's cab and three B4 pr 04 (2nd class), one of which also has a brakeman's cab. All four cars are painted in bottle green (RAL 6007). The bogies correspond to the prototypical Prussian standard design. The much finer reproduction of the frames on the trap windows is pleasing to the eye.



**Photo above:**  
The new “compartment car” set (87655) comes in four pieces, and only the corresponding pack car is sold separately.

**Photo right:**  
A first tranche has also become available of the Mobile Station WLAN (60667) together with its complementary receiver box WLAN (60117).



About half of the Insider annual cars 2023 (80333) have arrived at the dealers. The model was once again a covered freight car of the GI Dresden type, used on the German Federal Railroad around 1972 (Era IV). It carries an advertising inscription “SABA” and has neither a brakeman's cab nor a platform.

The delivery of the Mobile Station WLAN (Art. No. 60667) has also begun. If the device is not operated with a Central Station, the WLAN receiver box (60117) is still required for operation. So far, only a first tranche of both is available; currently, they are not available ex-works. So, it will probably take a few more weeks until all customers will have access to them.

In addition to the wireless MS, the WLAN receiver box also enables the start-up infrared control units to be coupled and integrated for layout operation. In total, it can even couple up to four MS WLAN.

Configuring the devices should be easy via a web application or Central Station. We will test the devices extensively and report on our experiences with regard to Z gauge requirements.

## Useful things at Yellow Dwarf:

Yellow Dwarf (<https://www.yellowdwarf.eu>) has reported four new items that are very useful on the layout: Tree grids (item no. 60070) can probably be found in every city around trees planted in squares or other highly frequented areas.

But construction sites also offer their charm when they are loaded with the necessary construction material such as the pallets with Ytong blocks (60201) or lever blocks (60202). But they can also be used as loads on road and rail vehicles or in reloading scenes at the freight shed.

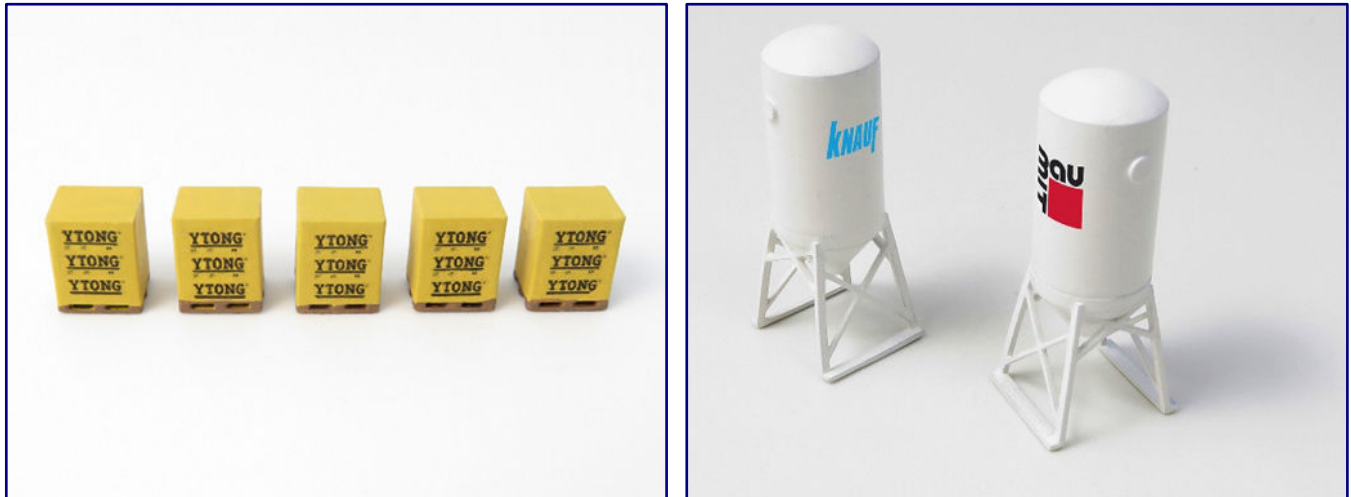

Among other things, pallets with Ytong blocks (Item No. 60201; photo left) and stand-up silos (60225; photo right) help equip Z-gauge construction sites. Photos: Yellow Dwarf

Back on the construction site, it is advisable to set up pedestal silos (60225), which form the fourth and last new product of this month.

## In search of personnel:

Modellbahn Union is looking for new workers for two positions at its Issum production site. Those who would like to turn their hobby into a profession can apply there as model railway technicians (N gauge) or as diorama builders. The latter position is to take care of the construction of new developments and their presentation.

Two short films about the job description at this provider are posted at the following links:

- Modelleisenbahntechniker (model railway technician) ([https://youtu.be/yI03wSnxcgk?si=\\_dyEgZZ5dgp7rwCb](https://youtu.be/yI03wSnxcgk?si=_dyEgZZ5dgp7rwCb))
- Dioramenbauer (diorama builder) (<https://youtu.be/y3EETNbiQAq?si=GT2W9m9EhLfIDoz4>)

You can reach the Model Railway Union at <https://www.modellbahnunion.com>.

Two new brochures by Stefan Carstens on open freight cars are announced as new items, available probably from October 16, 2023 (Part 1) and spring 2024 (Part 2).

## Faszination Modellbau at Bodensee (Lake Constance):

The Faszination Modellbau trade show will again be held in Friedrichshafen together with the Echtdampf-Hallentreffen (live steam meeting) from November 3 to 5, 2023. 22 model railroad layouts await visitors there, including a 24.5 x 8 metre module layout in Z gauge.



The “US Z-Lines Europe” are responsible for this giant exhibit based on models from North America and thus help to make this exhibition a visitor magnet for our scale. Trains up to 11 meters long with multiple diesel locomotives will run on this layout and clearly show the fans of larger scales what they lack the space for.



At Faszination Modellbau, US Z-Lines Europe want to wow visitors with seemingly endless trains. The layout on display also has record-breaking dimensions. Photo: Stephan Fuchs

Visitors will also not have to do without such popular steam locomotives as the “Challenger” or the “Big Boy”. In total, they show, as well as the separately built joint stand of the Z-Freunde International e.V. with other layouts and exhibits of various participants, what is feasible in our nominal scale.

For information on tickets, prices and opening hours required for a visit, please visit <https://www.faszination-modellbau.de>.

#### **Exciting from AZL:**

The National Train Show in the United States of America is the most important model railroad exhibition of the year. Traditionally, new products are also announced and presented there. American Z Lines makes no exception.

They are presented in more detail in a film report at the following web address: <https://youtu.be/dkPqhoBwjk0?si=gsgUKsIR5X75nlkC>. Topics in it are the EMD diesel locomotives SD50, SD60 and SD60M, the long-distance train “Coast Daylight” of the Southern Pacific including the legendary steam locomotive GS4, bulk freight cars “Ortner” and covered, modernized 40-foot AAR freight cars with single doors.

Out for delivery this month is FRISCO's striking EMD E8 with two different car numbers and locomotive names (Item Nos. 62621-1 / -2). The Trinity RAF column cars now carry 53-foot FedEx Multi-modal trailers (905202-1). Two such semi-trailers can also be purchased separately (954002-1).



Completing this roundup are the heavy Pennsylvania semi baggage cars (74003-1 to -3) on three-axle bogies. Returning to the program are the R-70-20 refrigerator cars of the SPFE as a two (914836-2) and four pack (904806-2).

FRISCO's EMD E8 (Item No. 62621-2) is certainly not overlooked on a layout. Photo: AZL / Ztrack

The same goes for the wide-view freight train escort car (921020-1 / -2), which we haven't seen for a few years. The first of several reissues is for the Alaska Railroad.

#### NoBa models fresh back:

Shortly before returning from the summer break, NoBa models has told us the autumn new products 2023. Equally new, however, is the significantly refreshed company logo, which now conveys the dynamism and innovative power of this supplier much better.



The Maypole with colourful decoration (item no. 10104) stands out from the other new products and the previous program. Photo (and logo top right): NoBa-Modelle

The Zetties can look forward to a table tennis table with players (item no. 10615R), two power distribution boxes for the roadside (11021R), a maypole with colorful decorations (10104), and a forklift suitable for eras III and IV (6513R).

As soon as production starts again, all four new products can be purchased directly from the manufacturer. Until then, the message "sold out" will appear in some cases, if no stock is available. The sales pages can be reached at <https://www.noba-modelle.de>.

#### New from Uhlenbrock:

Luisa is not a new employee at the Bottrop-based digital supplier Uhlenbrock. Instead, it is another creative abbreviation for a new product. The name stands for "LocoNet universal isolator, power supply and display" (Item No. 62 280).

This new LocoNet repeater with galvanic isolation via optocouplers creates a new LocoNet branch and refreshes the signals. It allows the connection of all Uhlenbrock LocoNet devices such as feedbacks and LocoNet boosters to all LocoNet-capable command stations with a non-grounded end stage.



For the second LocoNet branch Luisa also provides a power supply with 12 V and 500 mA for the “fresh” LocoNet connections. A suitable plug-in power supply is included.

Another autumn innovation is the power distributor with power supply connection socket (20 300). It was developed to transfer a previous task of a transformer to modern switching power supplies. Thus, it is not necessary to use a separate power supply for each device, but to supply several devices via this new product.

The power distributor has a DC socket for the power supply unit and 10 terminal pairs (+/-) for connecting the devices. The current carrying capacity is max. 5 A. For example, servo decoders or DC-operated lighting items can be connected. It can also be used to distribute traction current.

#### **New from Ratimo-Z:**

Even though electronic distribution at Rainer-Tielke-Modellbau is shut down for maintenance at the time of going to press, this supplier is by no means idle. For example, it has taken on the 3D printing of a concrete switching box for level crossings, which came out of ideas in the ZFI forum.



The switch houses for level crossings prints Ratimo-Z as a service for interested customers. The origin of the model construction is in the forum of Z-Friends International e.V.

Also, own ideas do not go out. For example, a letter to the editor already referred to the yellow luggage trailer (Item No. 50078) for the cart of the usual DB design already in the range. Interesting is also a white painted refrigerated trailer (50079), as it is used in the present time gladly at the edge of events for the storage of perishable goods, in order to be able to offer constantly fresh culinary specialties.

Our readers may not yet be familiar with a truck engine block (50081), which is used on forwarding agents' premises with their own workshop, but which can also be loaded onto the flatbed of a truck (or a freight car) just as effectively.

After completion of the maintenance work, Ratimo-Z can be reached again as usual at <https://www.rainer-tielke-modellbau.com>.



The yellow luggage trailer (item no. 50078; photo left) and the refrigerated trailer (50079; photo right), which is also offered as a finished model, are also current new items from the Ratimo-Z program that we have not yet presented here.

#### Azar Models works its way through:

In the truest sense of the word, French Z Gauge supplier Azar Models is working its way through: After locomotives and cars, the small-series manufacturer has now arrived at the end of the train. Working tail lights based on the SNCF example are to become available in the near future.

They are mounted on two versions of the covered UIC standard freight car G4. A contact is triggered in the roof of the model by a magnet (included) that can be used to turn the tail light on and off. The power supply for the two LEDs is provided by two included button cells (type LR48), which are hidden in the car body and should last for several days. In this way, the models are suitable for both analogue and digital operation.



The tail lights based on the SNCF model are a good idea because they make sense in layout operation. The chosen method of battery supply and contactless on/off switching by magnet also seems well thought out.

This new product is offered via the following car versions made of brown coloured plastic: G 4 freight car with brown standard ventilation flaps (Item no. W02-STX) and with bare metal aluminium ventilation flaps (W02-STAX). The tail lights are mounted on the car body approximately at the buffer distance above



them. The sales partner in Germany is the 1zu220-Shop. The manufacturer's pages with its information can be found at the following address: <https://azar-models.com>.

#### Latest information from Japan:

Z gauge is also still present in the land of the rising sun. Over the years, there have been many manufacturers there who have brought interesting products and innovations to the market. Some, however, left it at short market appearances or treat themselves to longer breaks – not so at Rokuhan.

This high-volume supplier has long since established itself as the number one on its home market for 1:220 scale and has been present there for more than ten years without interruption with its catalog goods. This also regularly includes new products, most recently in the area of shorties, which now also take up American and German models.



Rokuhan was well received by customers at the Model Train Show (JAM) in Tokyo in mid-August. The first complete sample of the Shinkansen Series 0, forefather of all high-speed trains, was also shown here. Photo: Rokuhan

The Shinkansen Series 0, however, promises to be a cracker, as it was the world's first high-speed train in 1964, making its debut for the Tokyo Olympics. Rokuhan has taken it up and implemented it in its original version, which is characterized by a different window size in addition to its blue-ivory paint scheme.

At the time of going to press, the manufacturer was expecting the first production models to be available. The train will probably also be offered in Germany as a complete twelve-piece set (Item No. T020-1). This is indicated by the good response to the announcement and distribution of information via digital media.

Among other things, Rokuhan received good feedback at the Model Train Show (JAM) in Tokyo, which took place from August 18 to 20, 2023. There, the Japanese market leader was represented with its own booth, where a complete sample of the forefather of all high-speed trains was also on display. However, it was explicitly emphasized that this response also came from foreign customers.

Other new products were also shown at this trade fair, which we will also discuss in our magazine, at least in part. In September and October, Rokuhan will also be present at exhibitions and trade fairs in its home market, where they will be able to get in touch and exchange information with end customers.

#### Autumn new products 2023 at Märklin:

Märklin's new 2023 fall items, which were announced just in time for the event in Göppingen, are also quite richly equipped for Z scale. The "Pantone Color of the Year 2023" car (Item No. 82163), which looks unconventional as well as colourful and lively, was immediately well received.

To be expected was the 2023 Christmas car (80633), which is traditionally introduced with this last instalment of new products. This year it is a Pwi blunderbuss baggage car that completes the last two predecessors to a Christmas train.



This year's Christmas car (Item No. 80633) competes for the customers' favour in gingerbread colour. The baggage car completes the blunderbusses of the two previous years to form a Christmas train. Photo: Märklin

It is base coated in brown colour and supplemented with Christmas prints. It is packed in a clear house, one half of which is colourless and the back is grey. With this the wagon can also be hung as a tree decoration.

The class 221 diesel locomotive (88208) holds a small surprise. With ocean blue ivory, it reproduces the most unpopular colour version on this locomotive type. But, this is also a part of railroad history and the contemporary successor of the earlier model is technically up to date, and, for the first time, now also gets functional red tail lights, presumably the interior of the V 2000 is used for this to a large extent.



Although the locomotive's prototype was used primarily in coal and steel traffic at its Oberhausen-Osterfeld out-of-service depot, as is also shown in the prototype photo in the new items brochure, Märklin has provided a set for container traffic (82664) as a matching car set. Four Lgjs 598 gondolas and an Sgs 693 are loaded with various 20- and 40-foot ISO containers.



The class 221 (88208; photo left) now gets a light change for the first time that also includes red tail lights. A five-piece container car pack with containers also from DB-TFG and DR (82664) is intended to complement it. Photos: Märklin

In addition to typical representatives of the eighties, they also show one each of the DB and the DR. Diesel locomotive and five-car packs are one-off MHI series, which also makes it clear how the special series for these dealers will be completed in 2023.



The package "Bauzug EfW" (81372) with four red-brown side-dump cars Fas 126 and one EfW diesel locomotive of the class 212 should now be available at dealers. Photo: Märklin

A German Federal Railroad “vacation train” set (81304) apparently has a guest worker train as a model. It consists of a chrome oxide green class 140 electric locomotive and three pairs of By3ge conversion cars in the condition around 1972. The cars have Era IV markings, we find the locomotive somewhat unimaginative because, as with the class 139 in ocean blue ivory, there is no variation and for almost 40 years the class designation seems to be firmly tied to one colour.

To a small series Aral tank cars makes another new product (82304) two previous predecessors. Once again, a two-axle old tank car with an attached adjusting shield appears. This time, it again wears a light grey colour and has a brakeman's cab. It is also set at the DB.

The MRCE Dispolok is the prototype of the black ES 64 electric locomotive from Siemens (88588). For the first time, this class enters the Mini Club assortment with the latest technology in a version with three single-arm pantographs.

The official end of the listing is the “Bauzug EfW” (81372) package. The four red-brown Fas 126 side dump cars from the DB AG stock, loaded with gravel, are led by a class 212 diesel locomotive.

True to Era VI, however, the purple locomotive painted according to the DB scheme no longer belongs to the former state railroad, but to the private company EfW (Verkehrsgesellschaft Eisenbahnfreunde Westerwald). By the way, more photos of the autumn new products can be found on our website in a separate message.

Not mentioned in the fall new products is another message car that Märklin will present on October 5, 2023. Consequently, we are not yet allowed or able to make any statements about the details of the offer at this point. Those interested in the model should therefore keep an eye on what information the manufacturer reveals on the due date.



**A new “Message Wagon” will be unveiled on October 5, 2023. As of today, the only thing known is that it will be dedicated for a second time to the Dutch artist Vincent van Gogh.**



## **New miniature car from Turin:**

After our report, Guido and Mirko, whose initial letters characterize their own brand GMmodelli Torino, have also received encouragement beyond the borders of Italy, and the two are continuing their work.

While the first Gauge Z model of an FS electric locomotive was certainly, due to the lack of foreign suitability of the prototype, rather exotic for the majority of the Z Gauge community, the situation is completely different with a new car model.

To our surprise, however, it was not a model from the local manufacturer Fiat (with its Lancia brand) that was chosen, but a classic from the Alfa Romeo factory halls in the north of Milan. The Alfa Romeo 75R, built from 1975 - 1983, is an icon of the brand, which bears the city emblem of the northern Italian metropolis in its logo.



With the Alfa Romeo 75R from the 1975 to 1983 model years, GMmodelli is producing an icon of recent automobile construction in Italy on a scale of 1:220. Photo: GMmodelli Torino

Supplied in a transparent plastic box, the tiny vehicle is finely handcrafted to an exact scale. A transparent glass replica allows a view of the replicated interior, while the exterior of the sporty runabout impresses with a red paint finish applied by spraying. Other colours are also planned for the future.

The distribution takes place in Italy via model railway stores, the manufacturer probably therefore does not have its own website. Interested parties can contact the two authors via GMmodelli[at]hotmail.com. We plan to present the new car model with our own photos in the magazine.

## **Atlas Model Railroad announces its own cars:**

Atlas Model Railroad announces a total of twelve variants from six different railroads, each with two operating numbers, for its rolling stock debut. Yes, you read that right: Having once said it would only enter the field of track material, freight cars based on US models now follow.

The 53-foot covered Evans car (box car) with double sliding doors (DPD) was selected. The prototypes were built in the sixties and seventies and were widely used. They often transported wood and paper products, but were also suitable for foodstuffs.

Sample images or technical descriptions are not yet available. We therefore show a manufacturer's drawing and refer to its pages for ongoing information and the variants offered, which can now be pre-ordered: <https://shop.atlasrr.com/c-1700-z01.aspx>.

Distribution in Germany is handled by, among others, Case Hobbies (<https://case-hobbies.de>).

#### Exhibitions in November and December:

It will also be an interesting fall for Z gauge outside of the larger trade shows. We have collected three exhibitions for you at which our size is represented or even plays the main role.

The first event will be the EHEH Model Railroad Days in the Hochdahl locomotive shed at the Hochdahl-Erkrath steep ramp, located between Düsseldorf and Wuppertal. They will take place on November 1, 4 and 5, 2023. The opening hours can be found on the organizer pages (<https://www.lokschuppen-hochdahl.de/wordpress/veranstaltungen/>).

A four-member delegation from **Trainini®** will also be taking part in this exhibition, presenting some exciting exhibits, holding technical discussions and, above all, offering free handicrafts for children.

The event continues with the Model Railroad Day in Duisburg. In the inland waterway museum, the enthusiasts around Markus Schiavo (<https://www.spur-n.com>) expect the visitors to the 6th hobby show, which has to offer besides railroad also ship model construction and other sections. On December 2 and 3, 2023, the exhibition will be open from 10:00 to 17:00.

In addition to Ralf Junius, Volker Bastek will also be present with a new layout for Z scale. According to our information, his brother André Kammels will again accompany him with his own exhibit. Torsten Schubert (Z-Lights) will show his illuminated model cars and give soldering demonstrations. This event is also supported by the Modellbahn Union.



We will certainly get to see the "Kistrath" layout of Ralf Junius this fall, as he is participating in all three events. This leaves Hochdahl, Duisburg, and Zell an der Mosel, as possible meeting places...



The highlight and end of the year for our Z scale will again be the Advent meeting in Zell (Mosel). Detailed information will be given by the Z-Freunde International e.V., as organizer.



A Trainini® handcraft and driving programme for children is to be offered again in Hochdahl and probably also in Zell an der Mosel.

On the 2nd weekend of Advent, Zetties will again meet for a glass of wine and a meal together in the little Moselle town. The meeting will start on Friday evening, 8 December 2023, depending on the arrival time of the participants, with a relaxed get-together at the old train station in Zell.

Saturday will be the set-up day for the exhibiting participants in the Zeller-Schwarze-Katz-Halle, near the entrance to the town on the main road. For the evening, we expect to have a meal together, for which we do not yet have any information. However, this has been a tradition for many years, as the focus is clearly on conviviality and being together.

Sunday (10 December 2023) is then the official exhibition day in the municipal hall from 10:00 a.m., entertaining and delighting visitors from near and far. Many Zetties who do not exhibit themselves also appear here to get up-to-date information and have nice conversations.

We have suggested that this event should also be listed under the Model Railway Day, registered on its campaign page and that its logo should be added to the event poster in order to further increase its reach and awareness outside the local area and the Z gauge community.

## Two deliveries by MTL:

The seventh wagon of the "War of the Worlds" series is now rolling in at Micro-Trains. It is an olive-green flat wagon (art. no. 525 00 182) loaded with a tank model that roughly reflects the time of the First World War.



The flat wagon loaded with a tank is number 7 of the "War of the Worlds" series (item no. 525 00 182; Photo left). In keeping with the season, another Halloween wagon appears (507 00 730; Photo on the right). Photos: Micro-Trains

In keeping with the season, a special Halloween model is also being released. Once again, a covered 40-foot freight wagon was chosen, which is printed with a matching motif around the company's own Micro Mouse (507 00 730).

## Latest news on JSS Electronics:

Newly designed pages and an expanded range of products are promised by JSS-Elektronik. Owner Jörg Seitz let us know that the new sales pages are now available and that he is adding new products to them every day. The new range of services also includes, for example, decoder installation for customers.

So, it's worth browsing this resurrected offer at <https://jss-elektronik.de>.



## Imprint

ISSN 2512-8035

Bibliographic information of the German National Library: The German National Library lists this publication in the German National Bibliography. Detailed bibliographical data and editions can be found in the DNB catalogue at <https://portal.dnb.de>.

The publication of **Trainini German Magazine for Z Gauge** is voluntary and non-commercial. **Trainini German Magazine for Z Gauge** does not aim for any sources of income. This publication is governed exclusively by German law.

Contributions marked by name exclusively reflect the personal opinion of the author. This is not necessarily the same as that of the editor or publisher. Unless otherwise indicated, photos are taken by the editor.

Board of Editors:  
Holger Späing (Editor-in-Chief)  
Harald Fried  
Dirk Kuhlmann  
Joachim Ritter

Correspondent North America:  
Robert J. Kluz

English translation:  
Alexander Hock, Christoph Maier, Oleksiy Mark, Martin Stercken

Further voluntary work: Stephan Fuchs, Ralf Junius (**Trainini TV**), Torsten Schubert

Licensed **Trainini Discussion Group** (<https://www.facebook.com/groups/1597746057122056/>): Michael Etz (**Trainini Locomotive Doctor**)

Publisher and Responsible in terms of German press law (V.i.S.d.P.) is Holger Späing, Am Rondell 119, 44319 Dortmund; Contact: 49 (0)231 9598 7867 or by e-mail to [redaktion\[at\]trainini.de](mailto:redaktion[at]trainini.de).

Advertisements of events and advertisements of third parties are free of charge, but will only be accepted after availability and recognisable Z gauge reference. They appear separately from the editorial part on the sole responsibility of the advertiser. Advertisements from small series providers always have priority.

Letters to the editor must be submitted in writing by post or e-mail to [leserbriefe\[at\]trainini.de](mailto:leserbriefe[at]trainini.de), stating the full name and address of the responsible reader, and are always welcome. Publication is reserved to the editorial staff. The editorial team always endeavours to present a representative picture and therefore to take every submission into account.

By submitting video clips, pictures, photos and drawings, the sender agrees to the publication and indemnifies the publisher against any possible claims by third parties. This expressly includes a future repetition in the magazine, **Trainini TV** as well as in brochures and posters.

All company names, trademarks and designations mentioned in this publication belong to the respective manufacturers or rights owners. Their reproduction takes place without guarantee of the free usability. For misprints, errors, price quotations, product descriptions, building specifications or transmission errors of any form whatsoever, the editorial staff and publisher assume no liability.

**Trainini German Magazine for Z Gauge** is published monthly (without guarantee) and is available to all interested model railroaders, especially fans of Z gauge, to download free of charge and for a limited time from <https://www.trainini.eu>. Downloading may incur third-party connection and network service provider costs. The placement of only the complete magazine on other domains is expressly permitted after it is no longer available on **Trainini**'s own webpages, and as long as the download is not offered for a fee. **Trainini TV** can be found at <https://www.youtube.com/TraininiTV>.

All contributions, videos, photos and reports are subject to copyright. Translation, commercial printing and any other form of reproduction, even in part, require the prior express consent of the publisher. Unauthorized commercial use will not be tolerated.

**Trainini®** is a legally protected trademark, registered in the register of the German Patent and Trademark Office (Munich), No. 307 30 512. The trademark is owned by Holger Späing, Dortmund. Misuse will not be tolerated. All rights reserved.